

POWER TRIM TILT ASSY 1

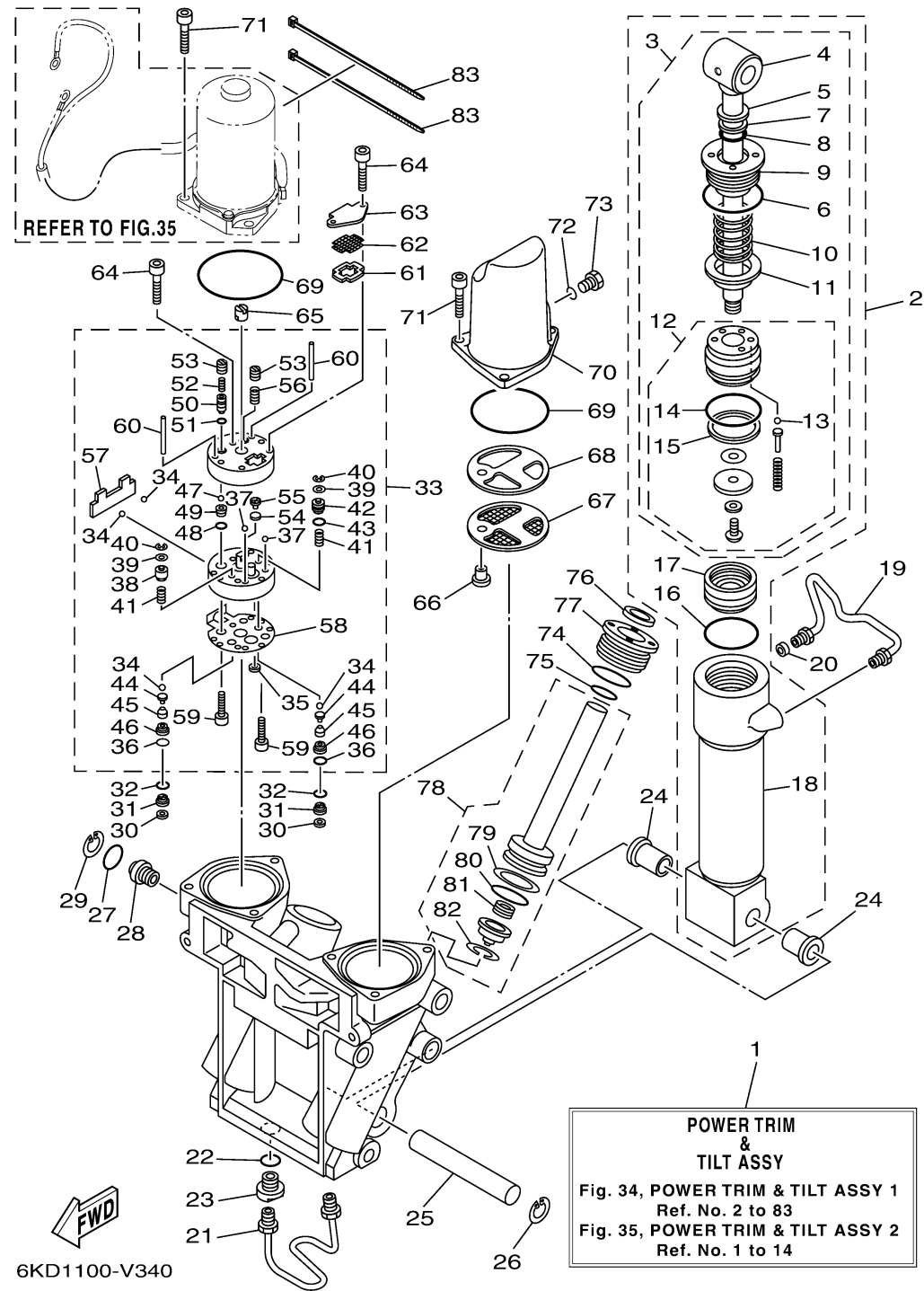

Ref No.	Part Number	Description	Qty	Remarks
1	6KA-W4380-01-8D	POWER TRIM & TILT ASSY	1	GRAY
1	6KA-W4380-01-CE	POWER TRIM & TILT ASSY	0	WHITE
1	6KA-W4380-01-CJ	POWER TRIM & TILT ASSY	0	WARM WHITE
2	6KA-43840-00-00	POWER TILT ASSY	1	
3	6KA-43810-00-00	..TILT PISTON SUB ASSY	1	
4	6KA-43801-00-00	...ROD	1	
5	93106-19001-00	...OIL SEAL	1	
6	63P-43861-20-00	...O-RING	1	
7	6H1-43872-00-00	...RING, BACK UP	1	
8	61A-4389H-01-00	...O-RING	1	
9	61A-43811-00-00	...SCREW, CYLINDER END	1	
10	69J-4384H-00-00	...SPRING	1	
11	69J-4382E-00-00	...ADAPTOR 2	1	
12	6CE-4380P-00-00	...PISTON SUB ASSY	1	
13	93505-32038-00	...BALL	5	
14	61A-43861-00-00	... O-RING	1	
15	61A-43871-00-00RING, BACK UP	1	
16	61A-43861-00-00	. O-RING	1	
17	6H1-43814-11-00	..PISTON, FREE	1	
18	61A-43813-02-00	..CYLINDER, TILT	1	

CONTINUED ON NEXT FRAME >

POWER TRIM TILT ASSY 1

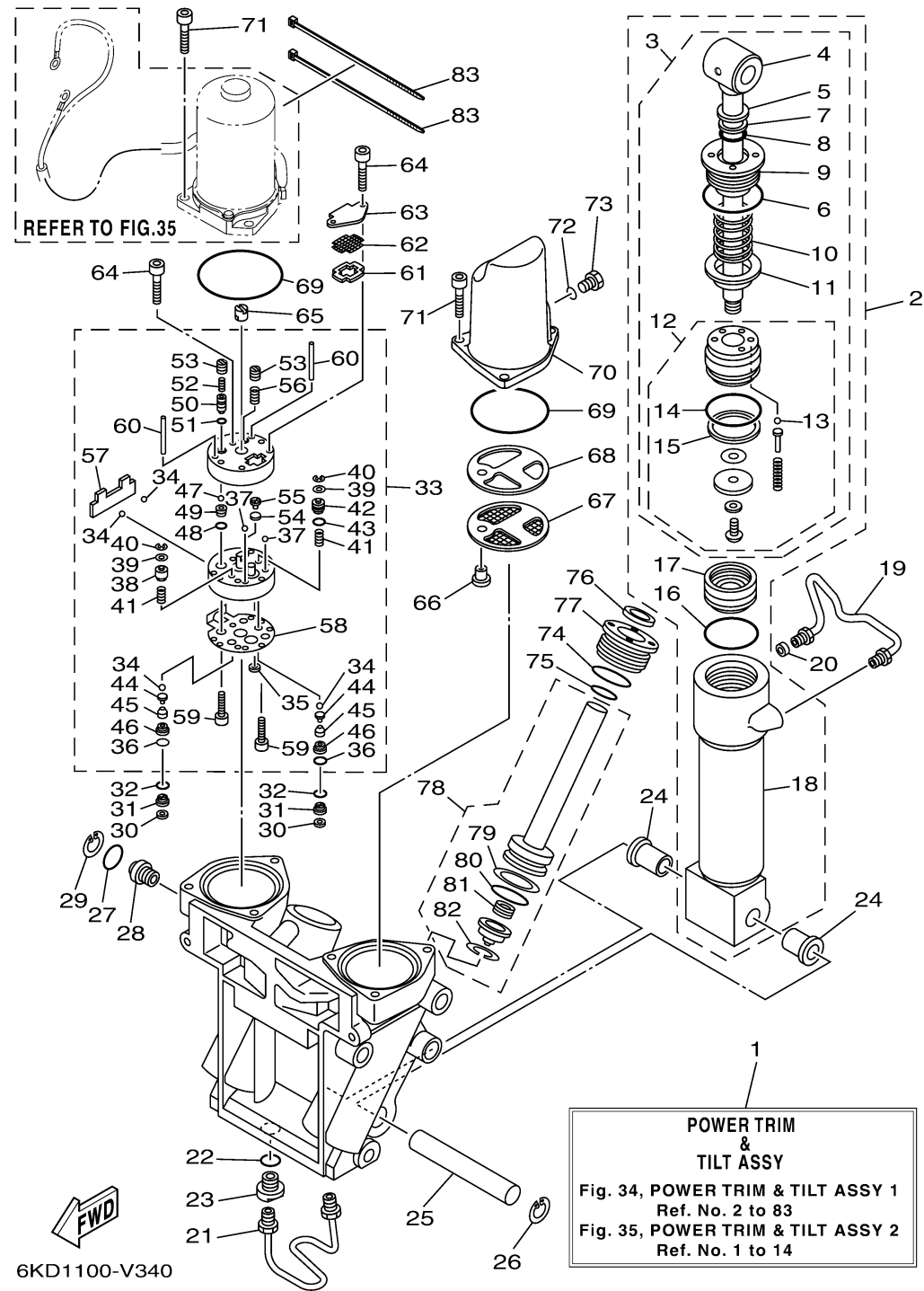

Ref No.	Part Number	Description	Qty	Remarks
19	69J-43835-10-00	PIPE	1	
20	69J-4388J-00-00	PLUG 2	1	
21	69J-43833-02-00	PIPE	1	
22	93210-17239-00	O-RING	1	
23	69J-4388E-01-00	BOLT ,SCREW	1	
24	90386-18M14-00	BUSH	2	
25	61A-43818-00-00	PIN, LOWER SHOCK MOUNT	1	
26	61A-43876-01-00	RING, SNAP	1	
27	6D8-43863-00-00	O-RING	1	
28	69J-43845-00-00	SCREW, MANUAL RELEASE	1	
29	6H1-43875-00-00	RING, SNAP	1	
30	69J-4381C-00-00	.FILTER 3	2	
31	69J-43899-01-00	PLATE STOPPER	2	
32	69J-4389J-00-00	.O-RING	2	
33	69J-43830-01-00	GEAR PUMP ASSY	1	
34	93505-32038-00	.BALL	4	
35	69J-4381C-00-00	.FILTER 3	1	
36	69J-4389J-00-00	.O-RING	2	
37	93503-16003-00	.BALL	2	
38	6CJ-4384M-00-00	.PISTON, SHUTTLE 2	1	

CONTINUED ON NEXT FRAME >

POWER TRIM TILT ASSY 1

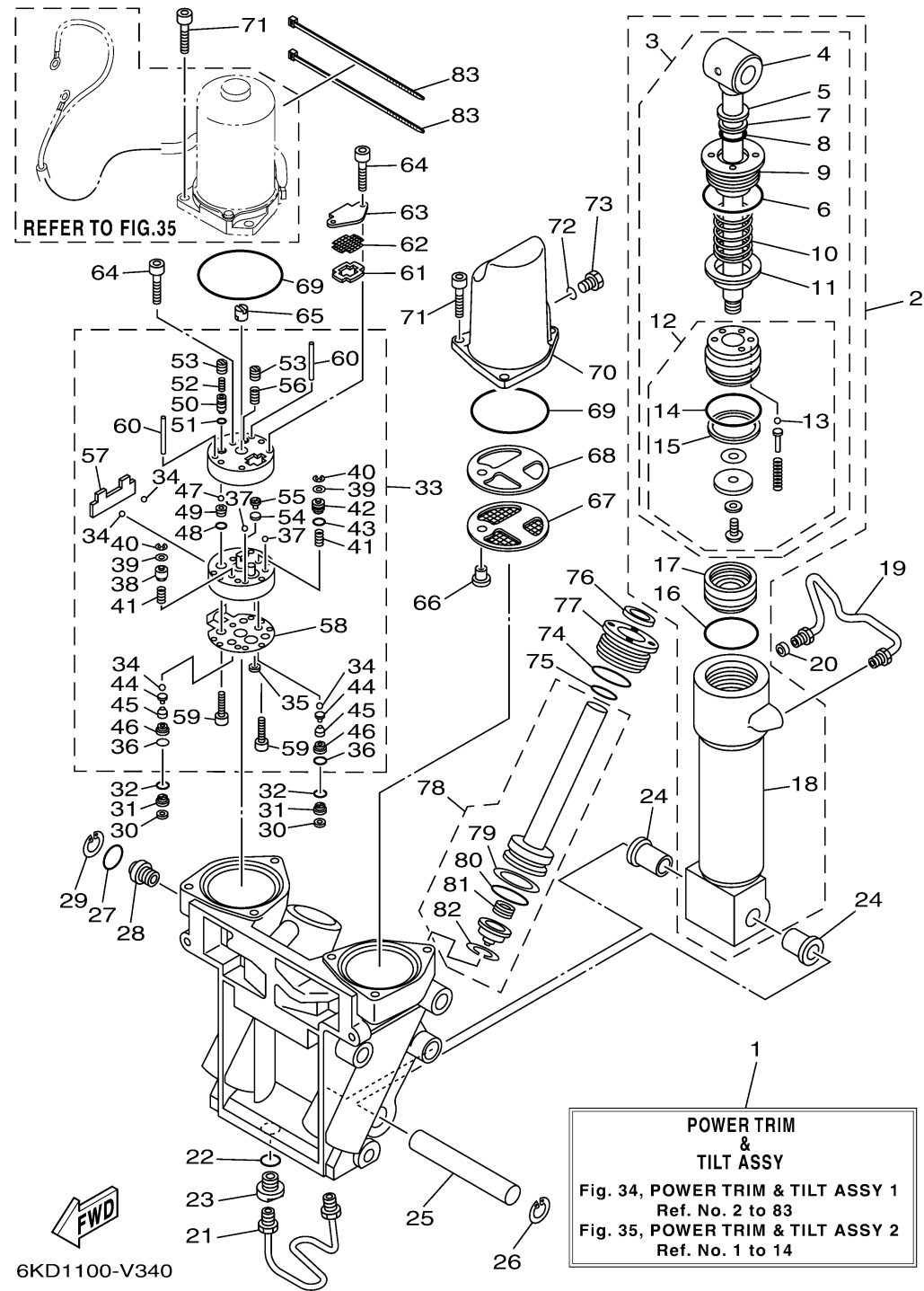

Ref No.	Part Number	Description	Qty	Remarks
39	69A-4384F-00-00	..SEAL, MAIN VALVE	2	
40	99002-03600-00	..CIRCLIP	2	
41	69J-43894-00-00	..SPRING, SHUTTLE RETURN	2	
42	6CJ-43841-00-00	..PISTON, SHUTTLE	1	
43	6H1-43883-00-00	..O-RING	1	
44	60V-4386A-00-00	..PIN, ABSORBER VALVE	2	
45	69J-43853-00-00	..SPRING, MAIN VALVE	2	
46	6CJ-43893-00-00	..WASHER	2	
47	93501-08001-00	..BALL	2	
48	93210-08391-00	..O-RING	1	
49	69J-43851-00-00	..SEAT, RELIEF VALVE	1	
50	63P-43844-20-00	..PIN, VALVE SUPPORT	1	
51	93210-064A5-00	..O-RING	1	
52	69J-43855-00-00	..SPRING, UP RELIEF	1	
53	6CJ-43843-00-00	..SCREW, VALVE LOCK	2	
54	6H1-4384G-11-00	..SEAL, RELIEF VALVE	1	
55	6H1-43844-10-00	..PIN, VALVE SUPPORT	1	
56	6H1-43856-10-00	..SPRING, DOWN RELIEF	1	
57	69J-43854-00-00	..SPRING, MANUAL RELEASE	1	
58	69J-4384G-00-00	..SEAL, RELIEF VALVE	1	

CONTINUED ON NEXT FRAME >

POWER TRIM TILT ASSY 1

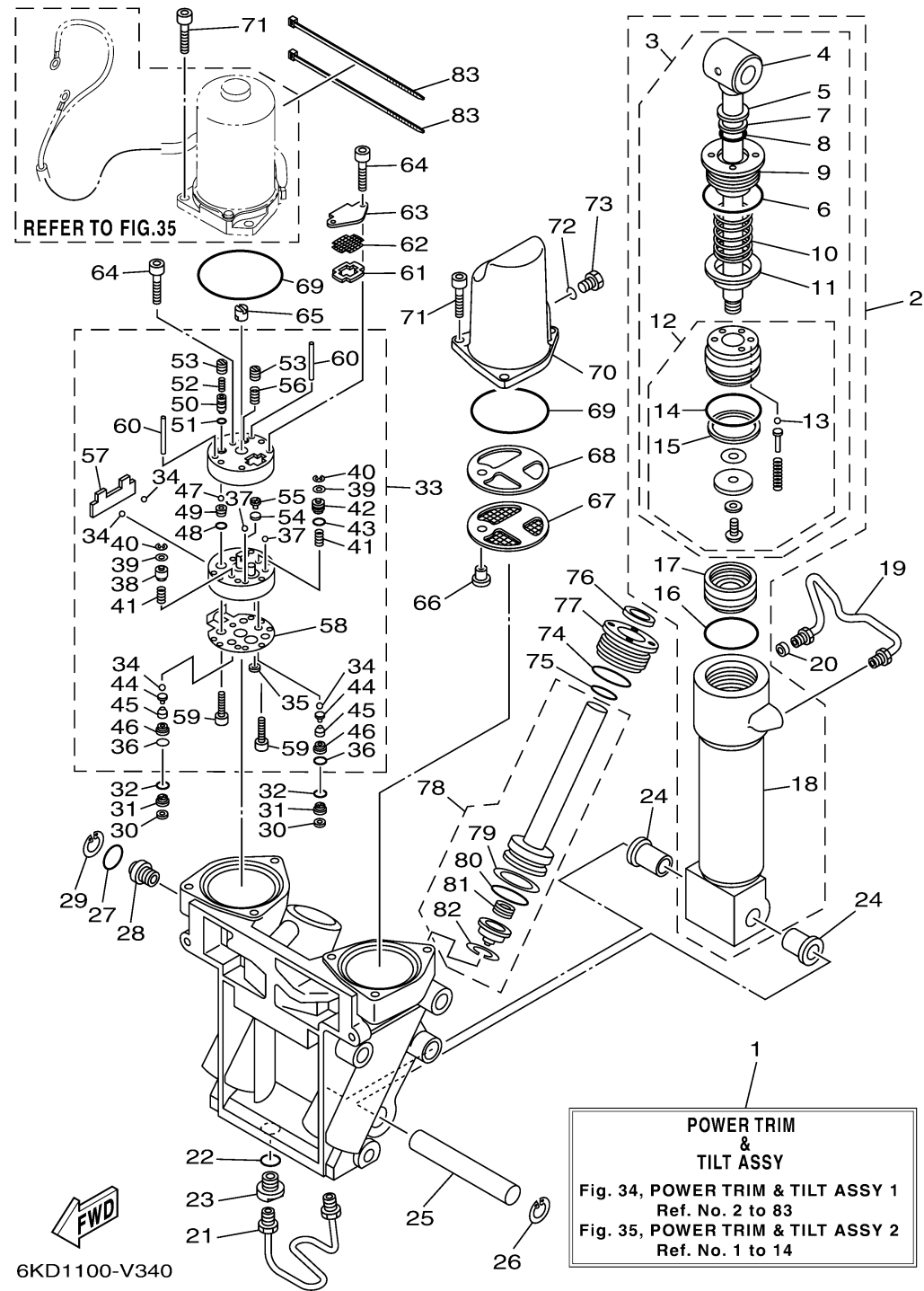

Ref No.	Part Number	Description	Qty	Remarks
59	91318-05025-00	. .BOLT	2	
60	93604-35236-00	. .PIN, DOWEL	2	
61	69J-43871-00-00	RING, BACK UP	1	
62	69J-43816-00-00	FILTER 1	1	
63	69J-4381J-00-00	PLATE	1	
64	91318-05040-00	BOLT	3	
65	69J-43831-00-00	CONNECTOR, SHAFT	1	
66	69J-4388H-00-00	PLUG	1	
67	69J-43817-00-00	FILTER 2	1	
68	69J-4388F-00-00	SPACER	1	
69	93210-66001-00	O-RING	2	
70	6KA-43828-00-00	BODY, RESERVOIR	1	
71	69J-43888-00-00	BOLT, SOCKET	6	
72	93210-09165-00	O-RING	1	
73	6H1-43829-00-00	PLUG, RESERVOIR	1	
74	61A-43861-00-00	O-RING	2	
75	6D8-43863-00-00	O-RING	2	
76	63P-43812-20-00	SEAL, DUST	2	
77	61A-43821-02-00	SCREW, TRIM CYLINDER END	2	
78	69J-43820-01-00	TRIM PISTON SUB ASSY	2	

CONTINUED ON NEXT FRAME >

POWER TRIM TILT ASSY 1

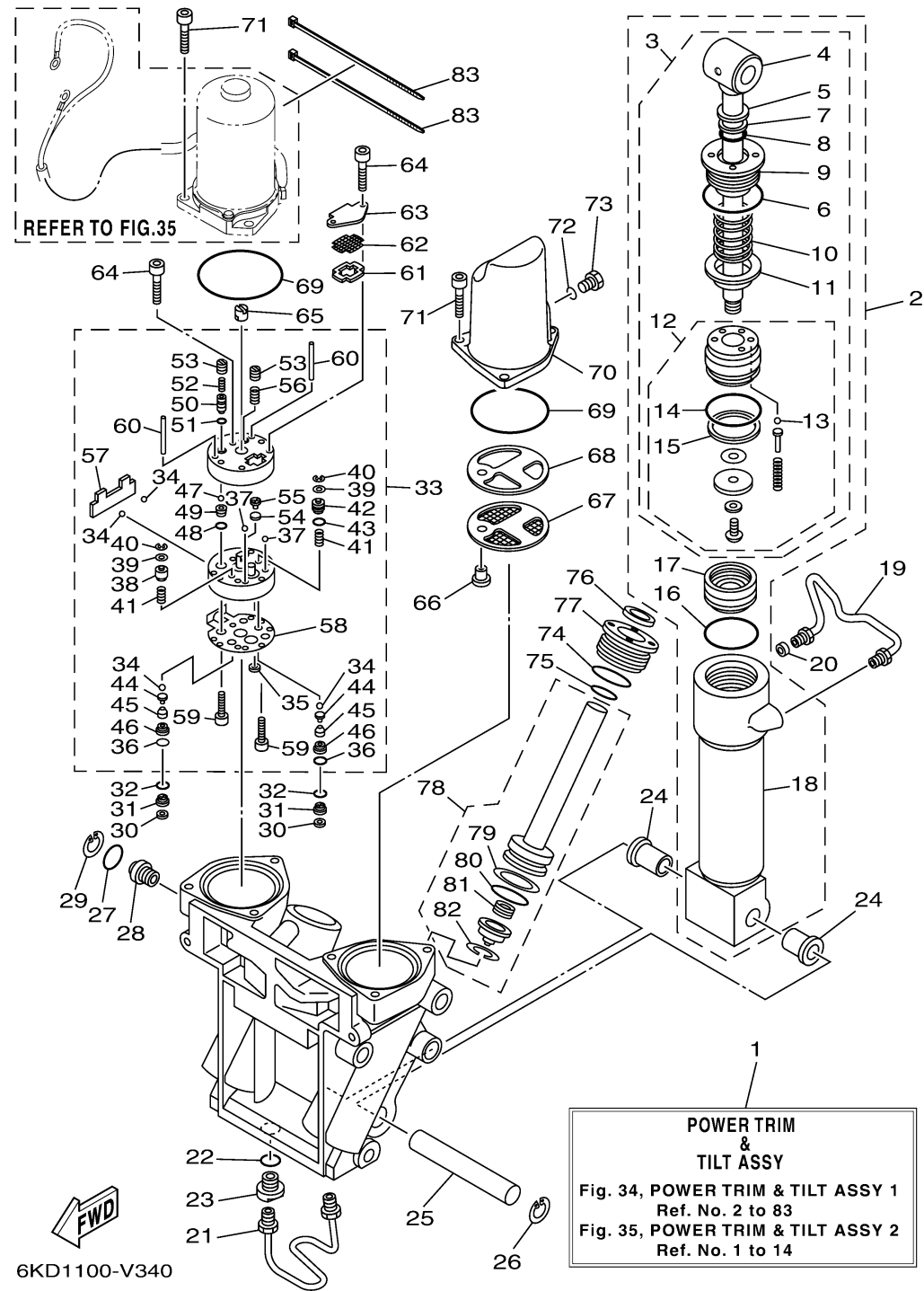

Ref No.	Part Number	Description	Qty	Remarks
79	61A-43874-00-00	.RING, BACK UP	1	
80	61A-43864-00-00	.O-RING	1	
81	61A-4384H-10-00	.SPRING	1	
82	61A-43875-10-00	.RING, SNAP	1	
83	90464-99004-00	CLAMP	2	