

COOLANT PRESSURE SENSOR

Kit Part No.	Remarks
60V-8A4L0-1B	F30B, F40F, F40L, F40N, F50L, FT50N, F60H, FT60J, F70B, F75D, F80D, F90C, F100F, F115B, FL115B, F130A, F150D, FL150D, F150F, FL150F

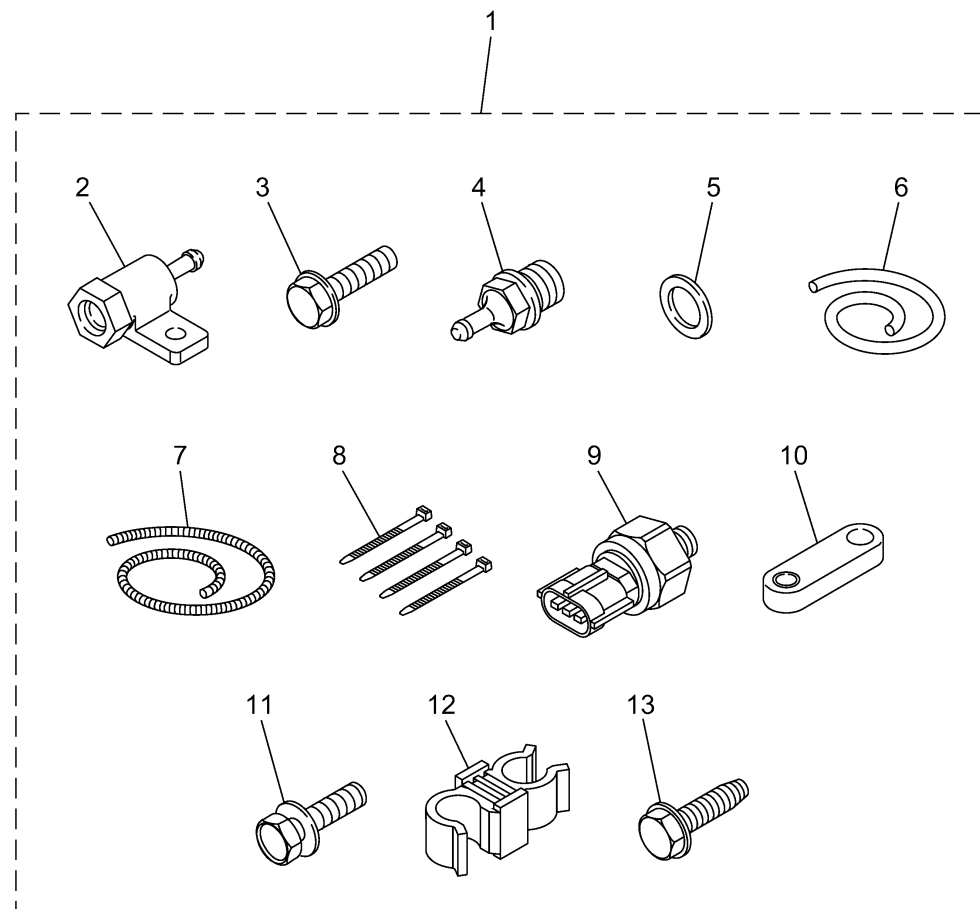

601M10M-Z140

DIGITAL NETWORK GAUGE 3

Ref No.	Part Number	Description	Qty	Remarks
1	60V-8A4L0-1B-00	SENSOR, MODULE	1	
2	60V-8366D-00-00	. .ADAPTOR, INPUT	1	
3	95D95-06025-00	. .BOLT, FLANGE DEEP RECESS	1	
4	60V-83667-00-00	. .SENDER, WATER PRESSURE	1	
5	90430-14115-00	. .GASKET	1	
6	90445-07018-00	. .HOSE (L1400)	1	
7	90447-07015-00	. .HOSE, COVER (L: 1300MM)	1	
8	90465-11M10-00	. .CLAMP	4	
9	6AW-8366B-10-00	. .SENSOR, WATER PRESSURE	1	
10	60V-8257V-00-00	. .PLATE, CONNECTOR	1	
11	97E95-06516-00	. .BOLT, HEXAGON W/W DEEP RECESS	1	
12	90464-09021-00	. .CLAMP	1	
13	90109-06M81-00	. .BOLT	1	