

SPEED/COOLANT PRESSURE SENSOR

Part No.	Remarks
60V-8A4L2-08	F115B, FL115B, F130A

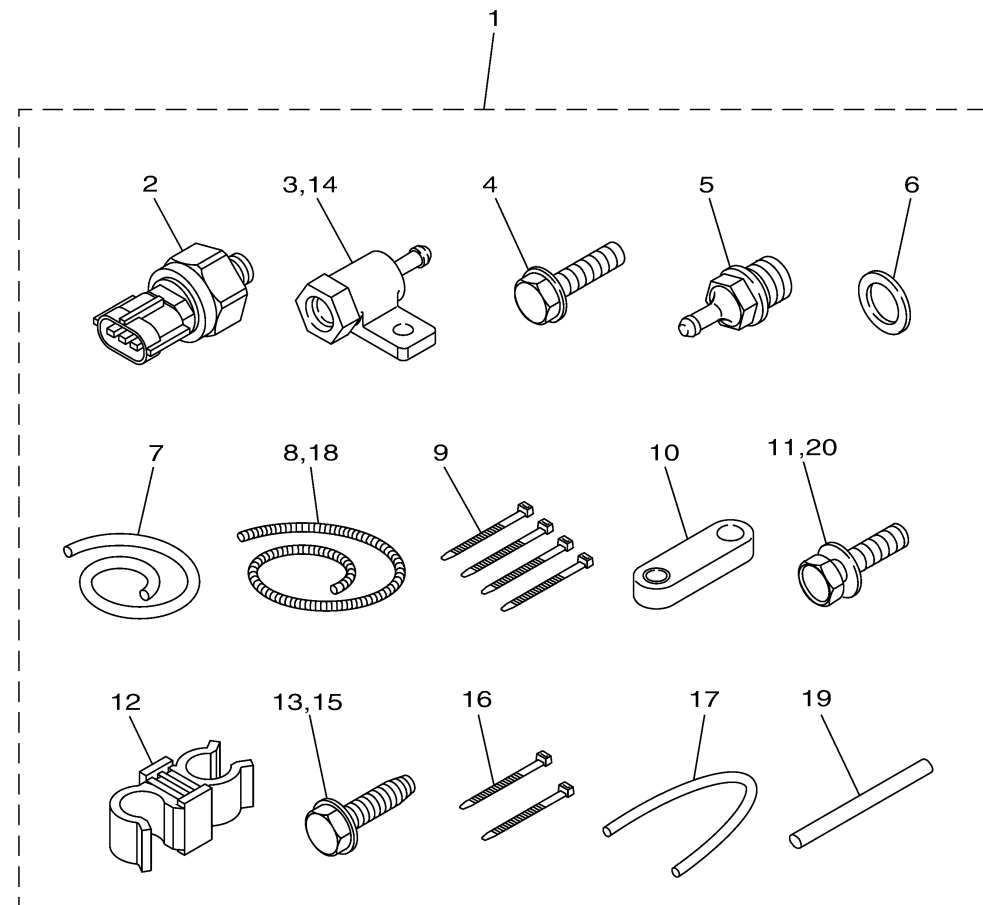

601M10M-W180

DIGITAL NETWORK GAUGE 7

Ref No.	Part Number	Description	Qty	Remarks
1	60V-8A4L2-08-00	SENSOR, MODULE 2	1	
2	6AW-8366B-10-00	. .SENSOR, WATER PRESSURE	2	
3	60V-8366D-00-00	. .ADAPTOR, INPUT	1	
4	95D95-06025-00	. .BOLT, FLANGE DEEP RECESS	1	
5	60V-83667-00-00	. .SENDER, WATER PRESSURE	1	
6	90430-14115-00	. .GASKET	1	
7	90445-07018-00	. .HOSE (L1400)	1	
8	90447-07015-00	. .HOSE, COVER (L: 1300MM)	1	
9	90465-11M10-00	. .CLAMP	4	
10	60V-8257V-00-00	. .PLATE, CONNECTOR	1	
11	97E95-06516-00	. .BOLT, HEXAGON W/W DEEP RECESS	1	
12	90464-09021-00	. .CLAMP	1	
13	90109-06M81-00	. .BOLT	1	
14	60V-8366D-00-00	. .ADAPTOR, INPUT	1	
15	90109-06M81-00	. .BOLT	1	
16	90465-11M10-00	. .CLAMP	2	
17	90445-07017-00	. .HOSE (L: 550MM)	1	
18	90447-07013-00	. .HOSE, COVER (L: 700MM)	1	
19	60V-42629-01-00	. .SEAL	1	
20	97E95-06516-00	. .BOLT, HEXAGON W/W DEEP RECESS	1	