

TWIN IG SWITCH

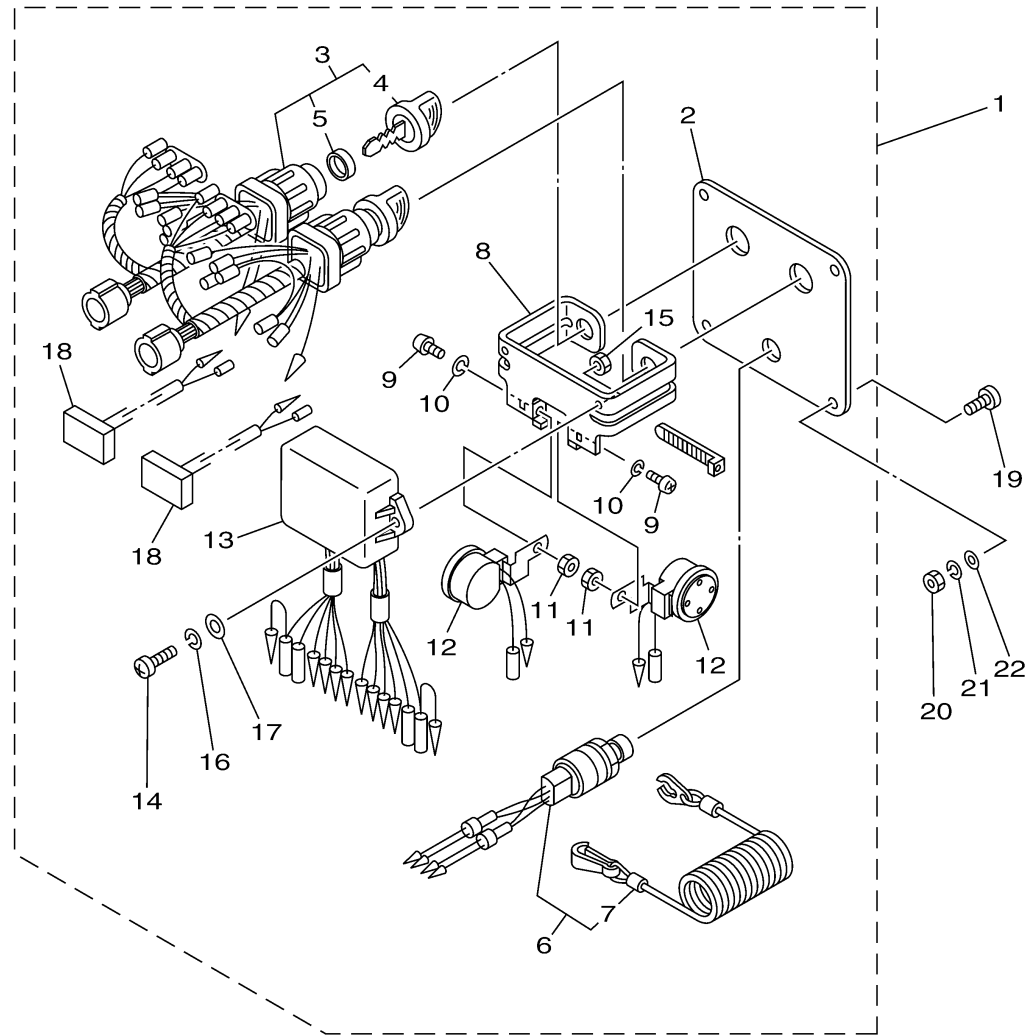

SWITCH & PANEL 6

Ref No.	Part Number	Description	Qty	Remarks
1	6K1-82570-16-00	PANEL SWITCH ASSY	1	WITH CHOKE SW.
2	6K1-82571-02-00	..PLATE, PANEL SWITCH	1	
3	6K1-82510-08-00	..MAIN SWITCH ASSY	2	
4	703-82577-00-00	...CAP, KEY	1	
5	6K1-82532-00-00	...CAP	1	
6	6K1-82575-01-00	..ENGINE STOP SWITCH ASSY	1	
7	682-82556-00-00	.. LANYARD, STOP SWITCH	1	
8	6K1-83614-01-00	..BRACKET	1	
9	98980-05010-00	..SCREW, BIND	2	
10	92990-05100-00	.. WASHER, SPRING	2	
11	95380-05600-00	..NUT	2	
12	688-83383-12-00	..BUZZER	2	
13	6K1-85830-04-00	..CONTROL UNIT ASSY	1	
14	98980-06020-00	..SCREW, BIND	2	
15	95380-06600-00	..NUT, HEXAGON	2	
16	92990-06100-00	.. WASHER, SPRING	2	
17	92990-06600-00	..WASHER, PLATE	2	
18	6K1-81980-00-00	..DIODE ASSY	2	
19	90149-05M05-00	SCREW	4	
20	95380-05600-00	..NUT	4	

CONTINUED ON NEXT FRAME >



601R10R-M310

TWIN IG SWITCH

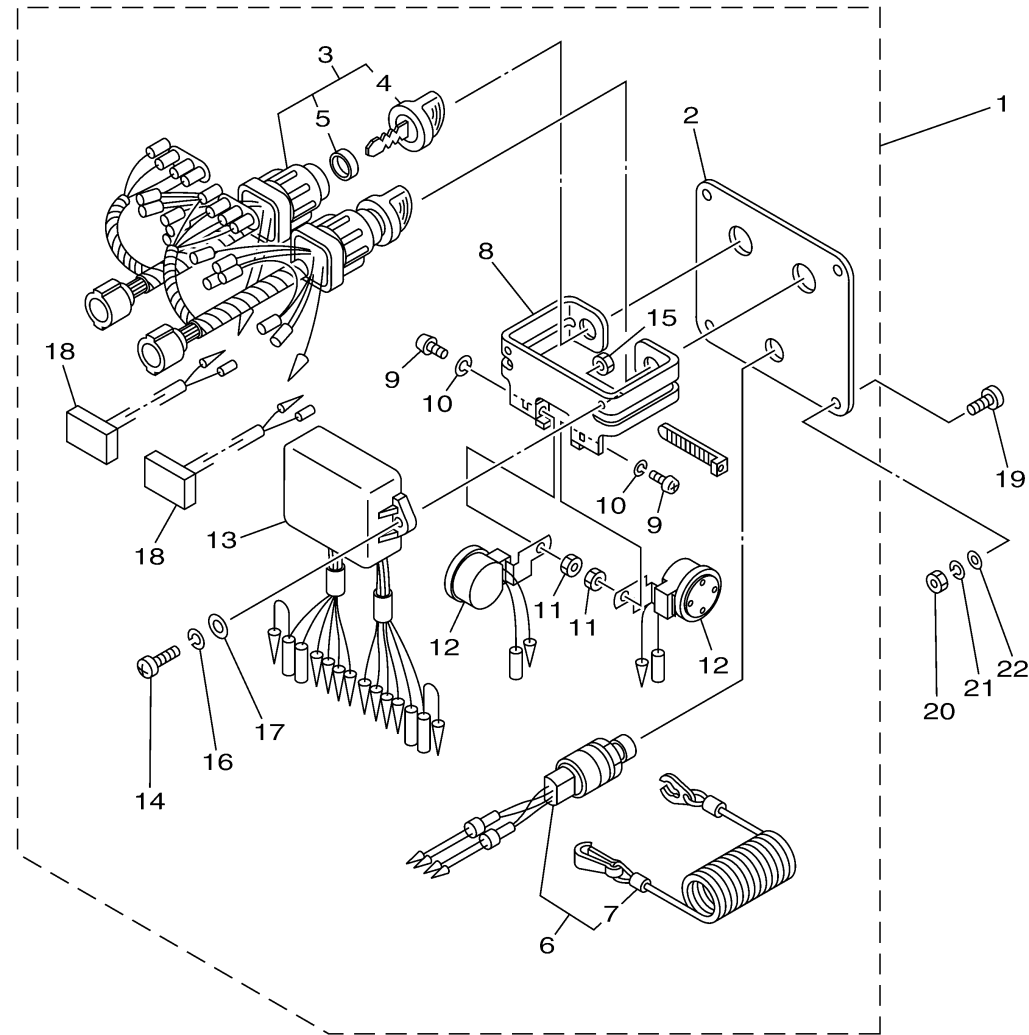

SWITCH & PANEL 6

Ref No.	Part Number	Description	Qty	Remarks
21	92990-05100-00	WASHER, SPRING	4	
22	92990-05600-00	WASHER, PLAIN	4	



601R10R-M310