

TWIN IG SWITCH

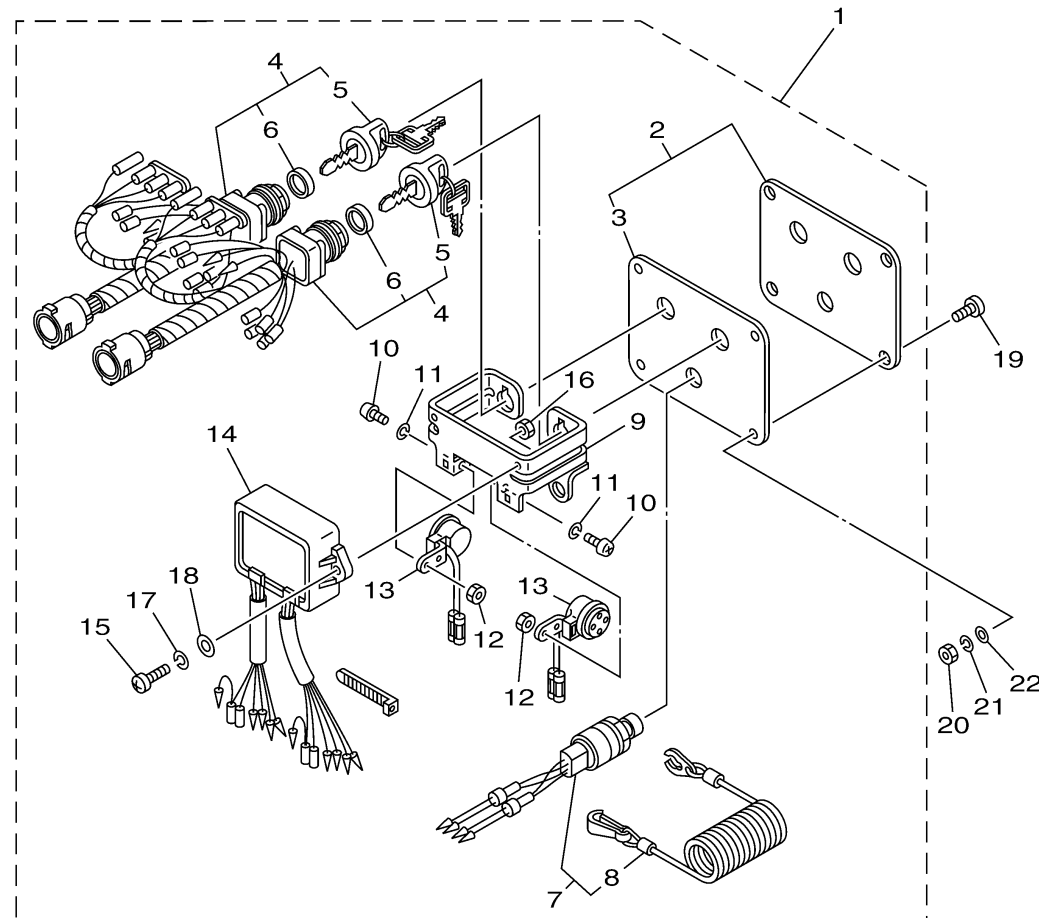

SWITCH & PANEL 7

Ref No.	Part Number	Description	Qty	Remarks
1	61B-82570-08-00	PANEL SWITCH ASSY	1	WITHOUT CHOKE SW.
2	6K1-82571-02-00	..PLATE, PANEL SWITCH	1	
3	61B-82588-01-00	...PLATE	1	
4	61B-82510-03-00	..MAIN SWITCH ASSY	2	
5	676-82577-01-00	...CAP, KEY	1	
6	703-82532-00-00	...CAP	1	
7	6K1-82575-01-00	..ENGINE STOP SWITCH ASSY	1	
8	682-82556-00-00	.. LANYARD, STOP SWITCH	1	
9	6K1-83614-01-00	..BRACKET	1	
10	98980-05010-00	..SCREW, BIND	2	
11	92990-05100-00	..WASHER, SPRING	2	
12	95380-05600-00	..NUT	2	
13	6R5-83383-00-00	..BUZZER	2	
14	61B-85830-02-00	..CONTROL UNIT ASSY	1	
15	98980-06020-00	..SCREW, BIND	2	
16	95380-06600-00	..NUT, HEXAGON	2	
17	92990-06100-00	..WASHER, SPRING	2	
18	92990-06600-00	..WASHER, PLATE	2	
19	90149-05M05-00	SCREW	4	
20	95380-05600-00	..NUT	4	

CONTINUED ON NEXT FRAME >



601R10R-K320

TWIN IG SWITCH

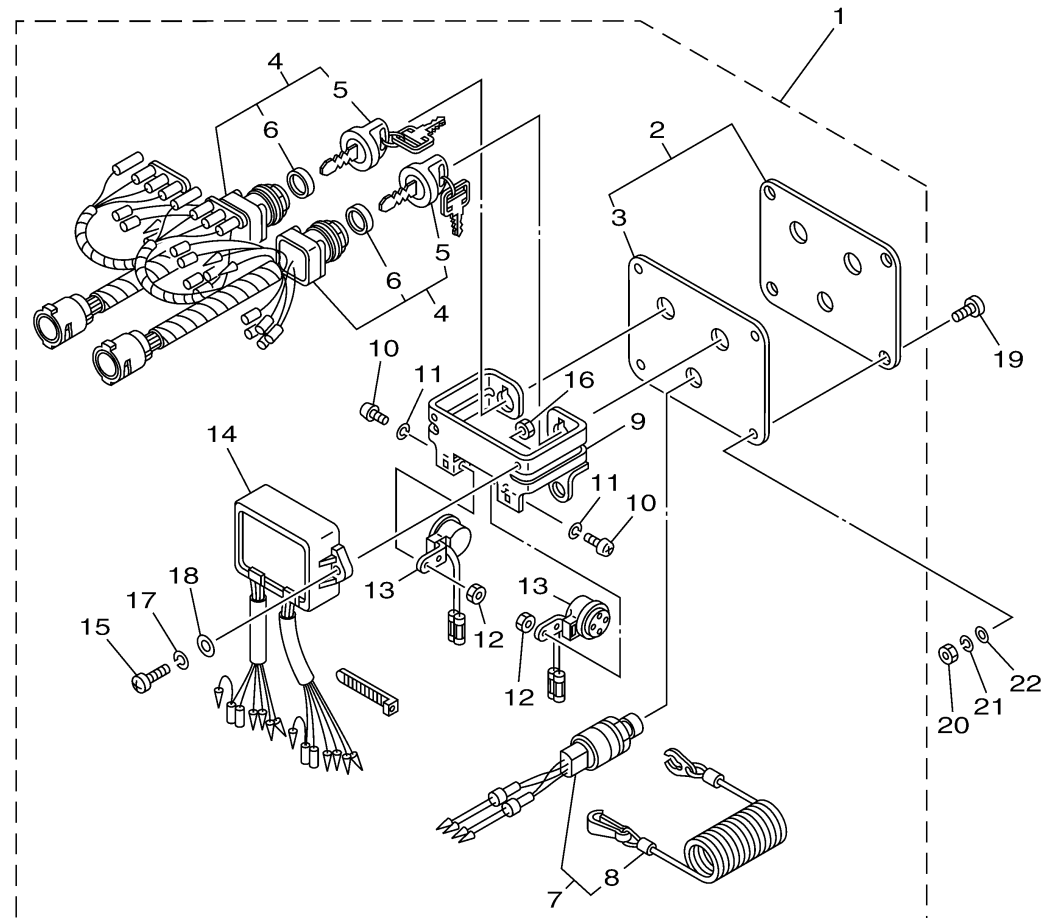

SWITCH & PANEL 7

Ref No.	Part Number	Description	Qty	Remarks
21	92990-05100-00	WASHER, SPRING	4	
22	92990-05600-00	WASHER, PLAIN	4	



601R10R-K320