

# CYLINDER CRANKCASE 2

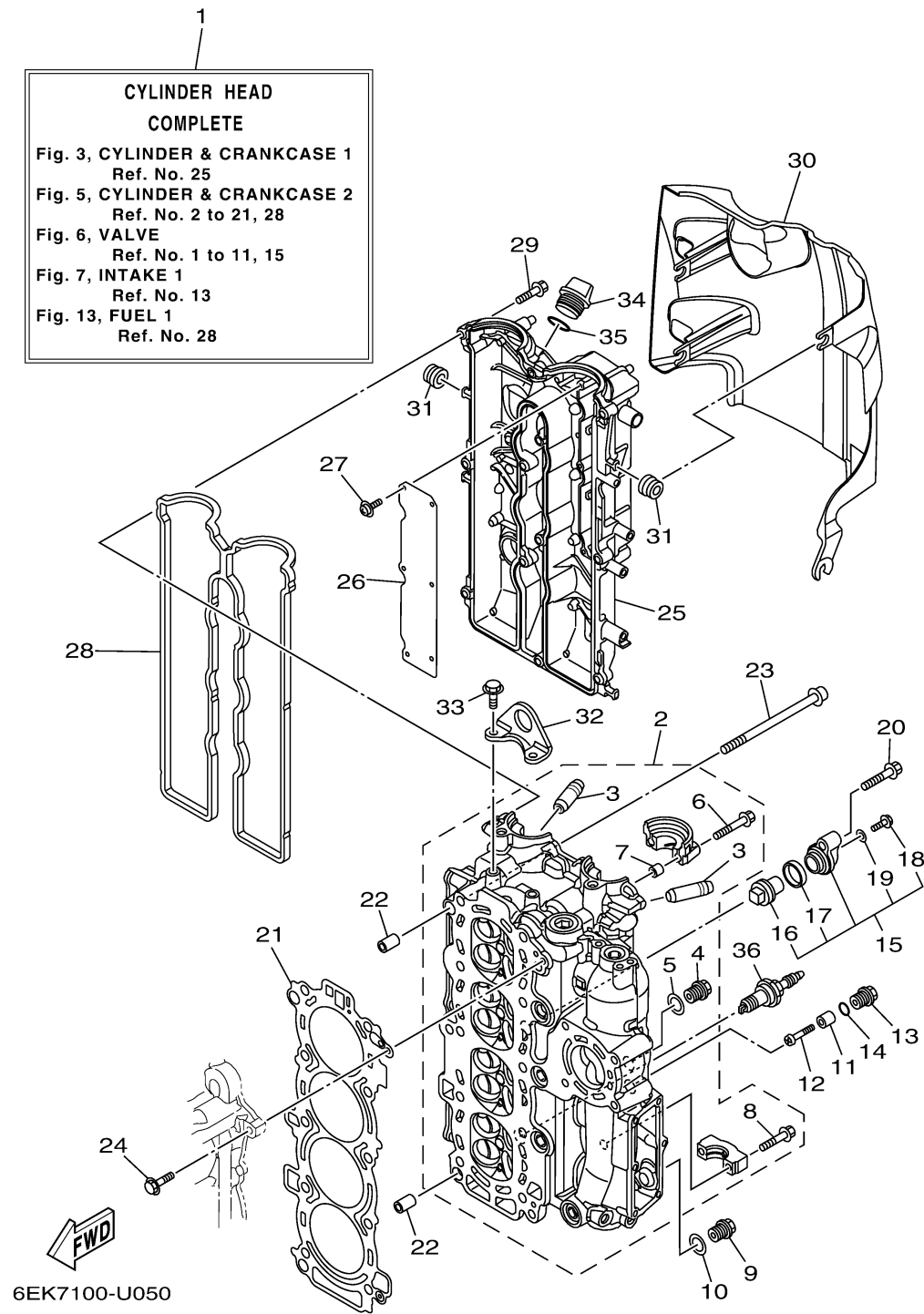

Ref No.	Part Number	Description	Qty	Remarks
1	6EK-W009A-02-9S	CYLINDER HEAD COMPLETE	1	
2	6EK-11110-00-9S	CYLINDER HEAD ASSY	1	
3	6DA-11133-10-00	. .GUIDE, VALVE 1	16	
4	90340-18M09-00	. .PLUG, STRAIGHT SCREW	1	
5	90201-186F1-00	. .WASHER, PLATE	1	
6	90119-07235-00	. .BOLT/WASHER-CAM CAPS	4	
7	91809-08006-00	. .PIN, DOWEL	4	
8	90119-07234-00	. .BOLT, WITH WASHER	16	
9	90340-14M06-00	PLUG, STRAIGHT SCREW	1	
10	90430-14115-00	.GASKET	1	
11	6G8-11325-00-00	ANODE	1	
12	98980-05025-00	SCREW, BIND	1	
13	6G8-11197-B0-00	PLUG, BLIND	1	
14	93210-13M63-00	.O-RING	1	
15	69J-11301-02-00	ANODE COVER ASSY	1	
16	6ML-11325-00-00	. .ANODE	1	
17	67F-11328-01-00	. .GROMMET, ANODE	1	
18	90105-06M07-00	. .BOLT, FLANGE	1	
19	90430-06M03-00	. .GASKET	1	
20	95D75-08040-00	BOLT, FLANGE DEEP RECESS	1	

CONTINUED ON NEXT FRAME >

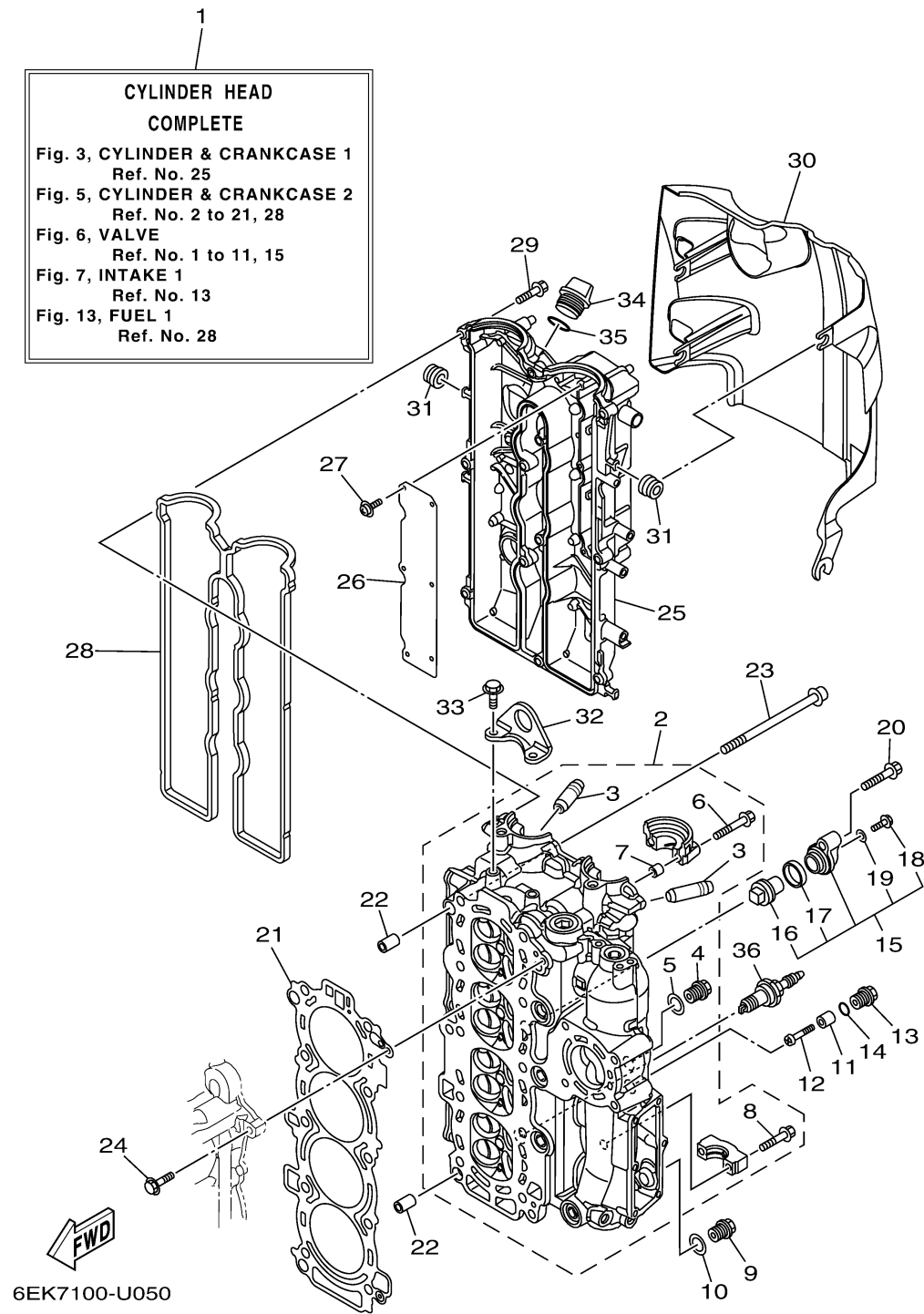

## CYLINDER CRANKCASE 2

Ref No.	Part Number	Description	Qty	Remarks
21	6EK-11181-00-00	.GASKET, CYLINDER HEAD 1	1	
22	99530-14016-00	PIN, DOWEL	2	
23	90149-10072-00	SCREW	10	
24	90105-06037-00	BOLT, FLANGE	1	
25	6EK-11191-10-00	COVER, CYLINDER HEAD 1	1	
26	6EK-11168-00-00	COVER, BREATHER	1	
27	97607-04208-00	SCREW, WITH WASHER	6	
28	6EK-11193-00-00	.GASKET, HEAD COVER 1	1	
29	95D95-06030-00	BOLT, FLANGE DEEP RECESS	12	
30	6EK-11192-01-00	COVER, CYLINDER HEAD 2	1	
31	90480-12314-00	GROMMET	4	
32	6EK-11119-00-00	HANGER, ENGINE	1	
33	95D95-08020-00	BOLT, FLANGE DEEP RECESS	2	
34	6G8-15363-00-00	PLUG, OIL	1	
35	93210-24M79-00	.O-RING	1	
36	LKR-6E000-00-00	PLUG, SPARK (NGK LKR6E)	4	