

ELECTRICAL 2

Ref No.	Part Number	Description	Qty	Remarks
1	63P-W8195-00-00	RELAY ASSY	1	
2	682-82119-01-00	COVER, LEAD WIRE	2	
3	97E95-06610-00	BOLT, HEXAGON W/W DEEP RECESS	2	
4	97E95-06520-00	BOLT, HEXAGON W/W DEEP RECESS	2	
5	6EK-81952-10-00	HOLDER, RELAY	1	
6	60V-85564-00-00	GROMMET	4	
7	90387-06176-00	COLLAR	4	
8	90119-06328-00	BOLT, WITH WASHER	4	
9	95D95-06016-00	BOLT, FLANGE DEEP RECESS	2	
10	6EK-81942-10-00	COVER	1	
11	90169-05M00-00	SCREW, TRUSS HEAD TAPPING	3	
12	90465-13M76-00	CLAMP	1	
13	90465-11M52-00	CLAMP	1	
14	90464-10M32-00	CLAMP	1	
15	90464-08004-00	CLAMP	1	
16	90464-12183-00	CLAMP	1	
17	6FP-82170-02-00	FUSE BOX ASSY	1	
18	6FP-82151-01-00	..FUSE (50A)	2	
19	6CB-82151-20-00	..FUSE (20A)	3	
20	6CB-82151-30-00	..FUSE (30A)	2	

CONTINUED ON NEXT FRAME >

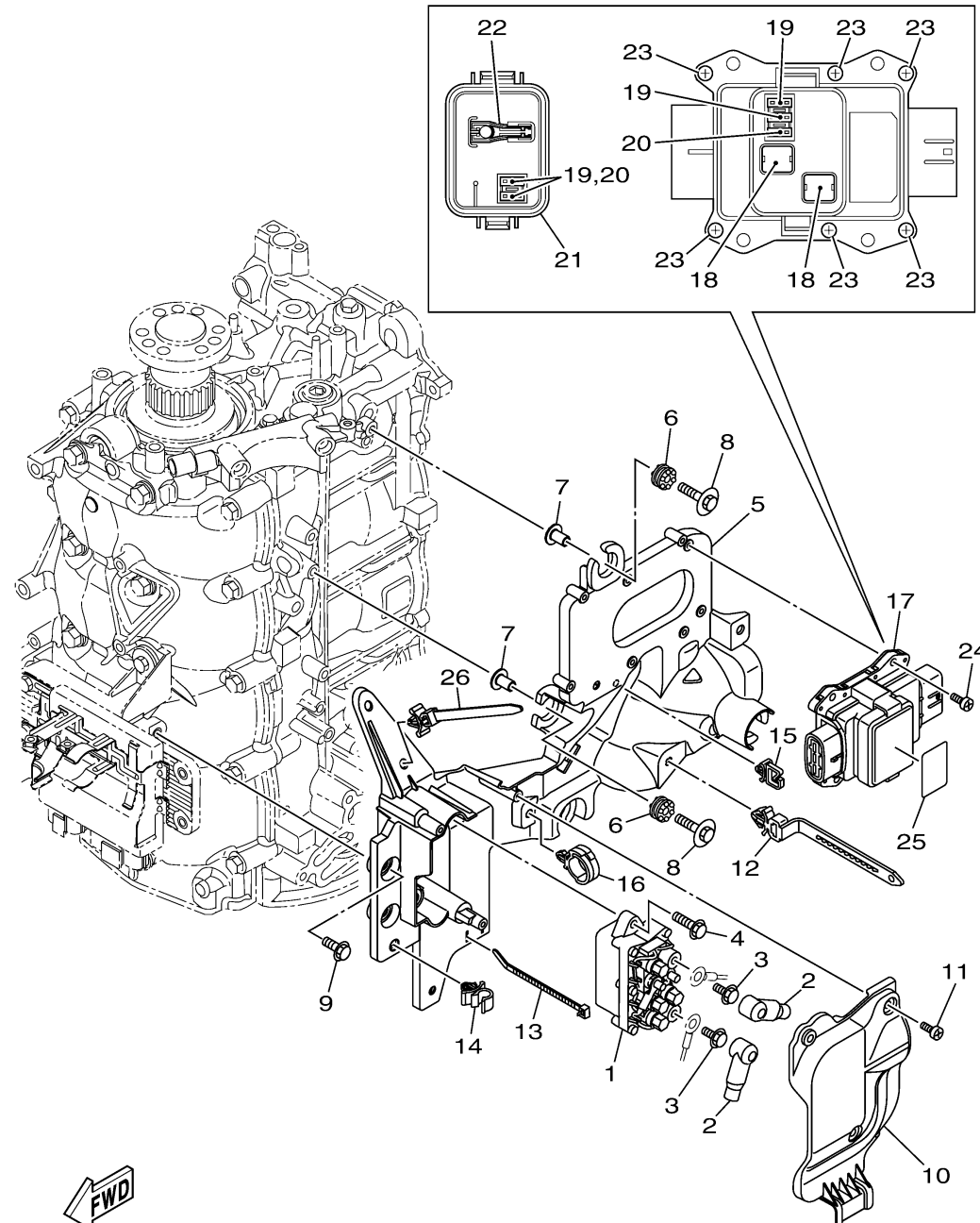

6EK6100-T170

ELECTRICAL 2

Ref No.	Part Number	Description	Qty	Remarks
21	6FP-85544-00-00	. .COVER	1	
22	6CB-2812A-00-00	. .PULLER, FUSE	1	
23	6P2-82113-00-00	. .SCREW (M3)	6	
24	97780-50620-00	SCREW, TAPPING	4	
25	6EK-81919-11-00	GRAPHIC, REGULATOR	1	
26	90465-12M56-00	CLAMP	1	

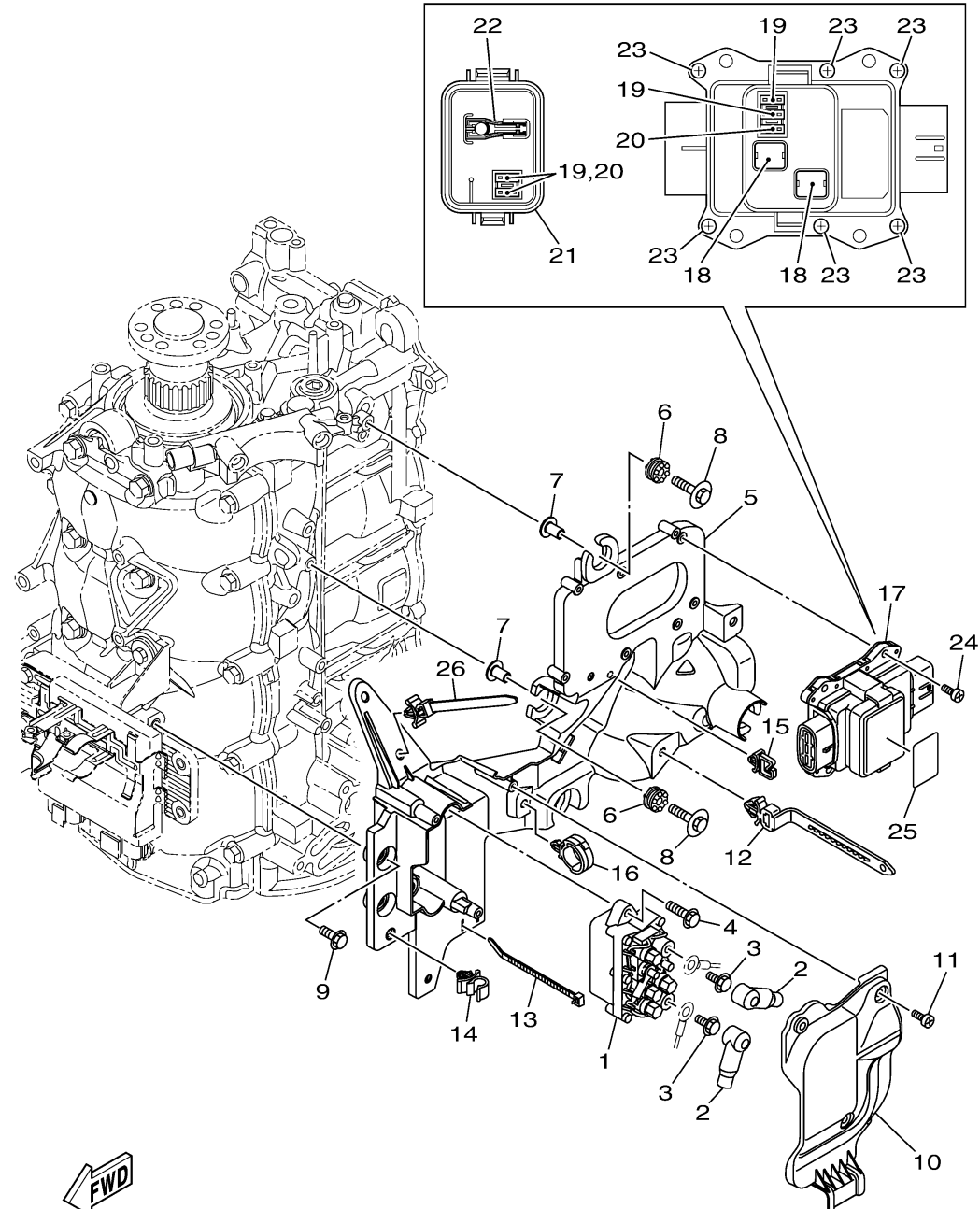

6EK6100-T170