

BOTTOM COWLING 1

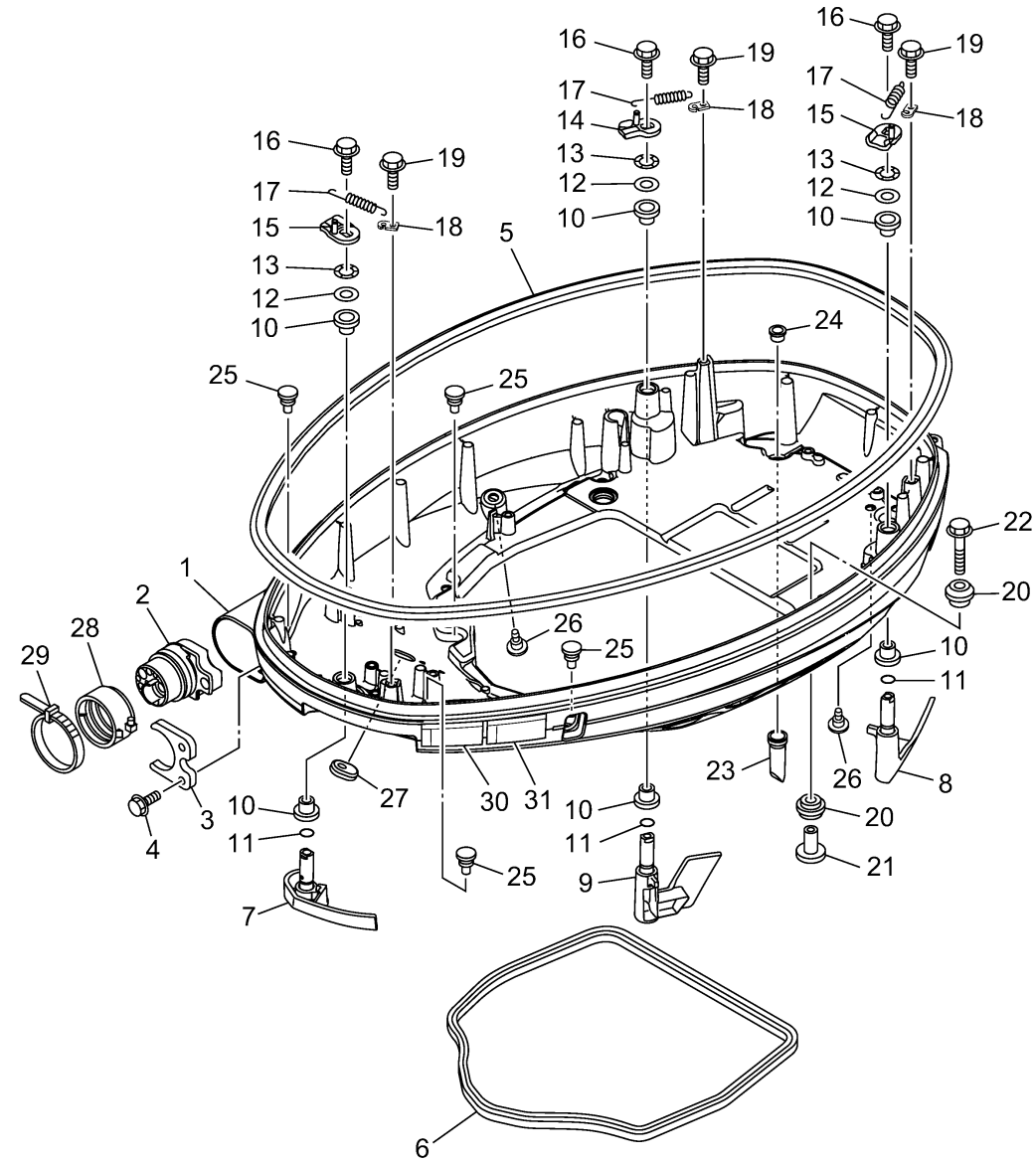

Ref No.	Part Number	Description	Qty	Remarks
1	6MA-42710-00-8D	BOTTOM COWLING ASSY	1	GRAY
1	6MA-42710-00-CE	BOTTOM COWLING ASSY	0	WHITE
2	6DA-42725-03-00	GROMMET	1	
3	6CB-42761-00-00	STOPPER	1	
4	90109-06316-00	BOLT	2	
5	6LH-42615-00-00	SEAL	1	
6	63P-42716-01-00	RUBBER SEAL 1	1	
7	6MA-42815-00-8D	LEVER, CLAMP 1	1	GRAY
7	6MA-42815-00-CE	LEVER, CLAMP 1	0	WHITE
8	6LH-42816-00-8D	LEVER, CLAMP 2	1	GRAY
8	6LH-42816-00-CE	LEVER, CLAMP 2	0	WHITE
9	6LH-42817-00-8D	LEVER, CLAMP 3	1	GRAY
9	6LH-42817-00-CE	LEVER, CLAMP 3	0	WHITE
10	90386-15M73-00	BUSH	6	
11	93210-13M63-00	.O-RING	3	
12	90201-156J2-00	WASHER, PLATE	3	
13	90206-15M18-00	WASHER, WAVE	3	
14	6CB-42818-00-00	LEVER, CLAMP 4	1	
15	6CB-42819-00-00	LEVER, CLAMP 5	2	
16	95D95-08012-00	BOLT, FLANGE DEEP RECESS	3	

CONTINUED ON NEXT FRAME >

6MA310E-Z200

BOTTOM COWLING 1

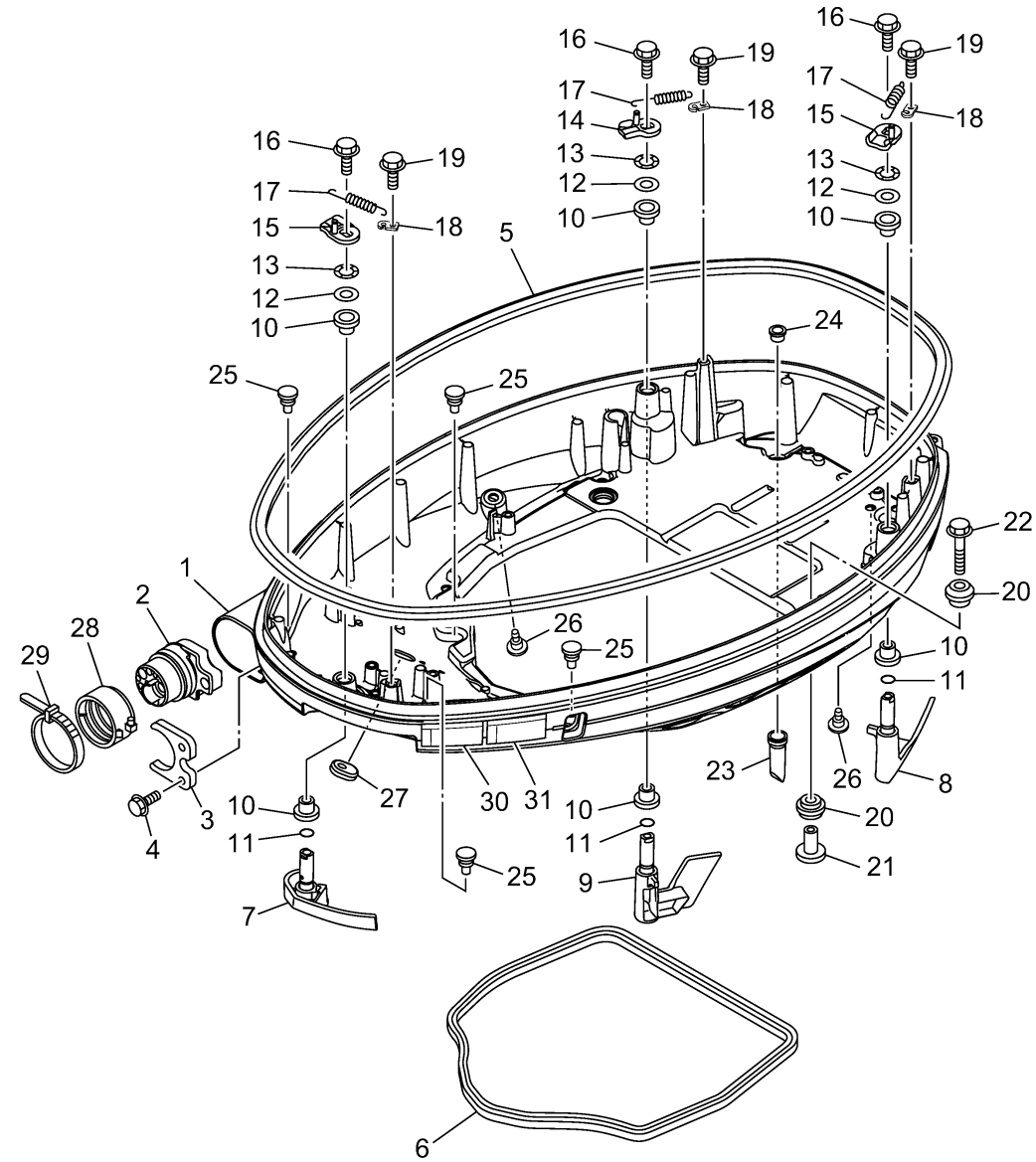

Ref No.	Part Number	Description	Qty	Remarks
17	90506-22001-00	SPRING, TENSION	3	
18	66T-43144-00-00	HOOK, SPRING	3	
19	90109-06316-00	BOLT	3	
20	90480-22M81-00	GROMMET	8	
21	90387-08M37-00	COLLAR	4	
22	90119-08187-00	BOLT, WITH WASHER	4	
23	6DA-42717-01-00	RUBBER, SEAL 2	4	
24	6DA-42384-00-00	SEAL, CAP	4	
25	6H4-42748-01-00	GROMMET	4	
26	6P2-44391-00-00	NIPPLE, HOSE	2	
27	6KA-42727-00-00	GROMMET	1	
28	68F-42753-00-00	FASTNER	1	AP
29	90464-20258-00	CLAMP	1	AP
30	6EE-42794-41-00	LABEL, WARNING (GENERAL)	1	
31	6EE-42794-51-00	LABEL, WARNING (GENERAL)	1	

 6MA310E-Z200