

# BRACKET 1

Ref No.	Part Number	Description	Qty	Remarks
1	6LH-43111-00-8D	BRACKET, CLAMP 1	1	GRAY
1	6LH-43111-00-CE	BRACKET, CLAMP 1	0	WHITE
2	6AW-45251-00-00	ANODE	1	
3	6G5-44526-00-00	PLATE	2	
4	97E95-06530-00	BOLT, HEXAGON W/W DEEP RECESS	4	
5	6LH-43112-00-8D	BRACKET, CLAMP 2	1	GRAY
5	6LH-43112-00-CE	BRACKET, CLAMP 2	0	WHITE
6	93700-06002-00	NIPPLE, GREASE	2	
7	6LH-43333-00-00	BUSH. , SWIVEL BRACKET	2	
8	6LH-43333-10-00	BUSH. , SWIVEL BRACKET	2	
9	6LH-43311-00-8D	BRACKET, SWIVEL 1	1	GRAY
9	6LH-43311-00-CE	BRACKET, SWIVEL 1	0	WHITE
10	93700-06002-00	NIPPLE, GREASE	1	
11	66K-82149-00-00	WIRE, LEAD 3	1	
12	6G5-43144-00-00	HOOK, SPRING	1	
13	97E95-06512-00	BOLT, HEXAGON W/W DEEP RECESS	1	
14	6LH-43181-00-00	LEVER, TILT STOP 1	1	
15	6LH-43185-00-00	LEVER, TILT STOP 2	1	
16	90386-10M16-00	BUSH	3	
17	6G5-43148-00-00	COLLAR, DISTANCE	2	

CONTINUED ON NEXT FRAME >

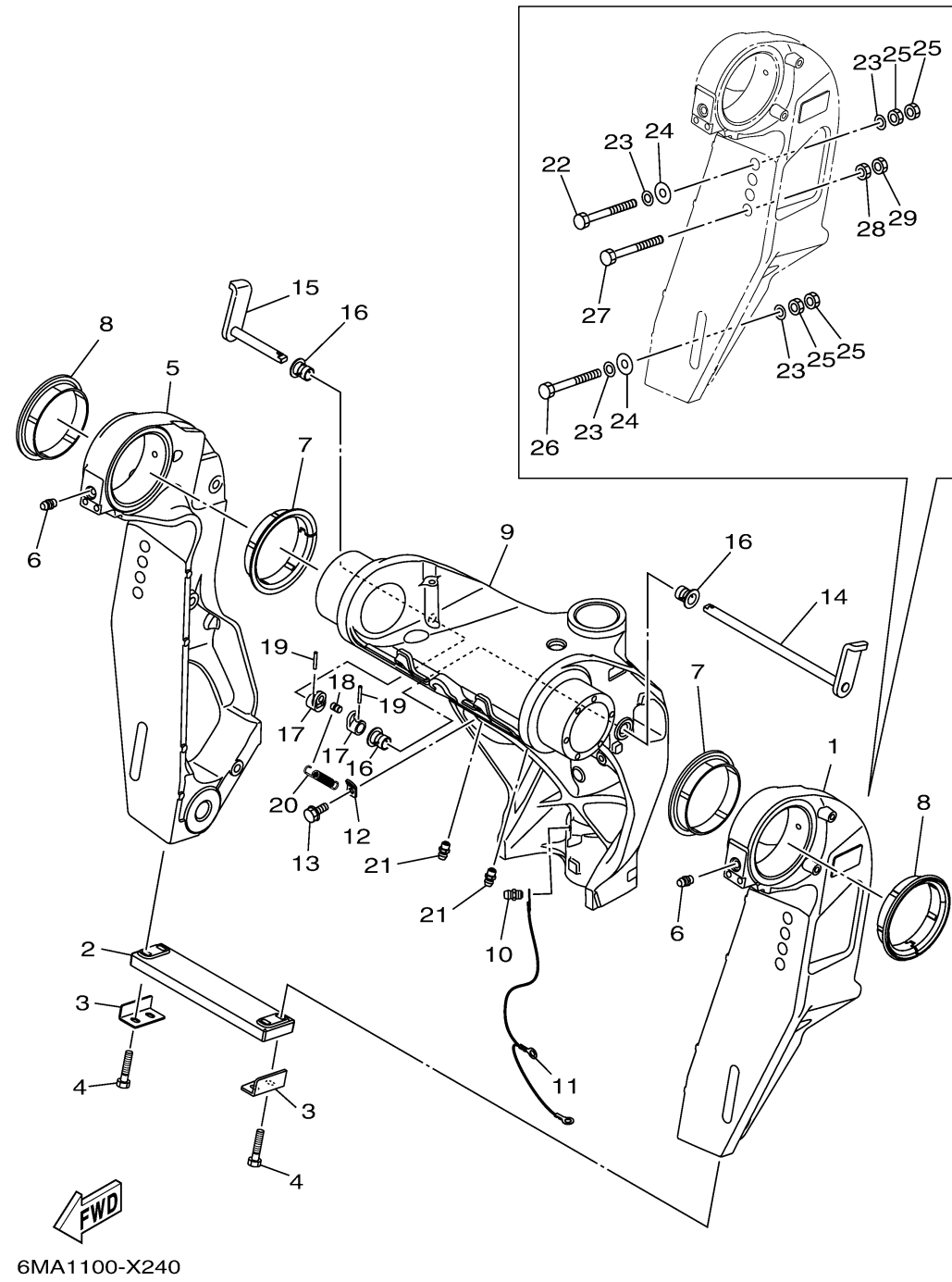

# BRACKET 1

Ref No.	Part Number	Description	Qty	Remarks
18	90249-06M19-00	PIN	1	
19	91690-30020-00	PIN, SPRING	2	
20	90506-16010-00	SPRING, TENSION	1	
21	93700-06002-00	NIPPLE, GREASE	2	
22	90101-12070-00	BOLT (230MM)	2	
23	90201-13M01-00	WASHER, PLATE	8	
24	90201-12426-00	WASHER, PLATE	4	
25	95380-12600-00	NUT	8	
26	90101-12066-00	BOLT (L:150MM)	2	
27	90101-12078-00	BOLT (L:220MM)	2	AP
28	95380-12700-00	NUT	2	AP
29	90170-12M28-00	NUT	2	AP