

# UPPER CASING

Ref No.	Part Number	Description	Qty	Remarks
1	63P-41137-07-CA	GUIDE, EXHAUST	1	
2	90119-08182-00	BOLT, WITH WASHER	2	
3	97E75-10545-00	BOLT, HEXAGON W/W DEEP RECESS	4	
4	93608-16M16-00	PIN, DOWEL	2	
5	90119-08189-00	BOLT, WITH WASHER	3	
6	97E75-10535-00	BOLT, HEXAGON W/W DEEP RECESS	4	
7	6E5-42724-01-00	GROMMET	1	
8	6LH-42769-00-00	SEAL, RUBBER	1	
9	63P-41131-02-00	MANIFOLD, EXT. 1	1	
10	63P-41133-A0-00	.GASKET, EXHAUST MANIFOLD 1	1	
11	97E75-08560-00	BOLT, HEXAGON W/W DEEP RECESS	4	
12	63P-14711-02-00	MUFFLER 1	1	
13	69J-45123-00-00	.GASKET, MUFFLER	1	
14	97E75-08535-00	BOLT, HEXAGON W/W DEEP RECESS	8	
15	93606-19M23-00	PIN, DOWEL	2	
16	63P-41134-A1-00	.GASKET, EXHAUST MANIFOLD 2	2	
17	63P-45181-02-00	PLATE	1	
18	63P-41138-00-00	.SEAL, EXT. 1	1	
19	69J-45127-01-00	.SEAL	1	
20	63P-45111-00-CE	CASING, UPPER	0	WHITE

CONTINUED ON NEXT FRAME >

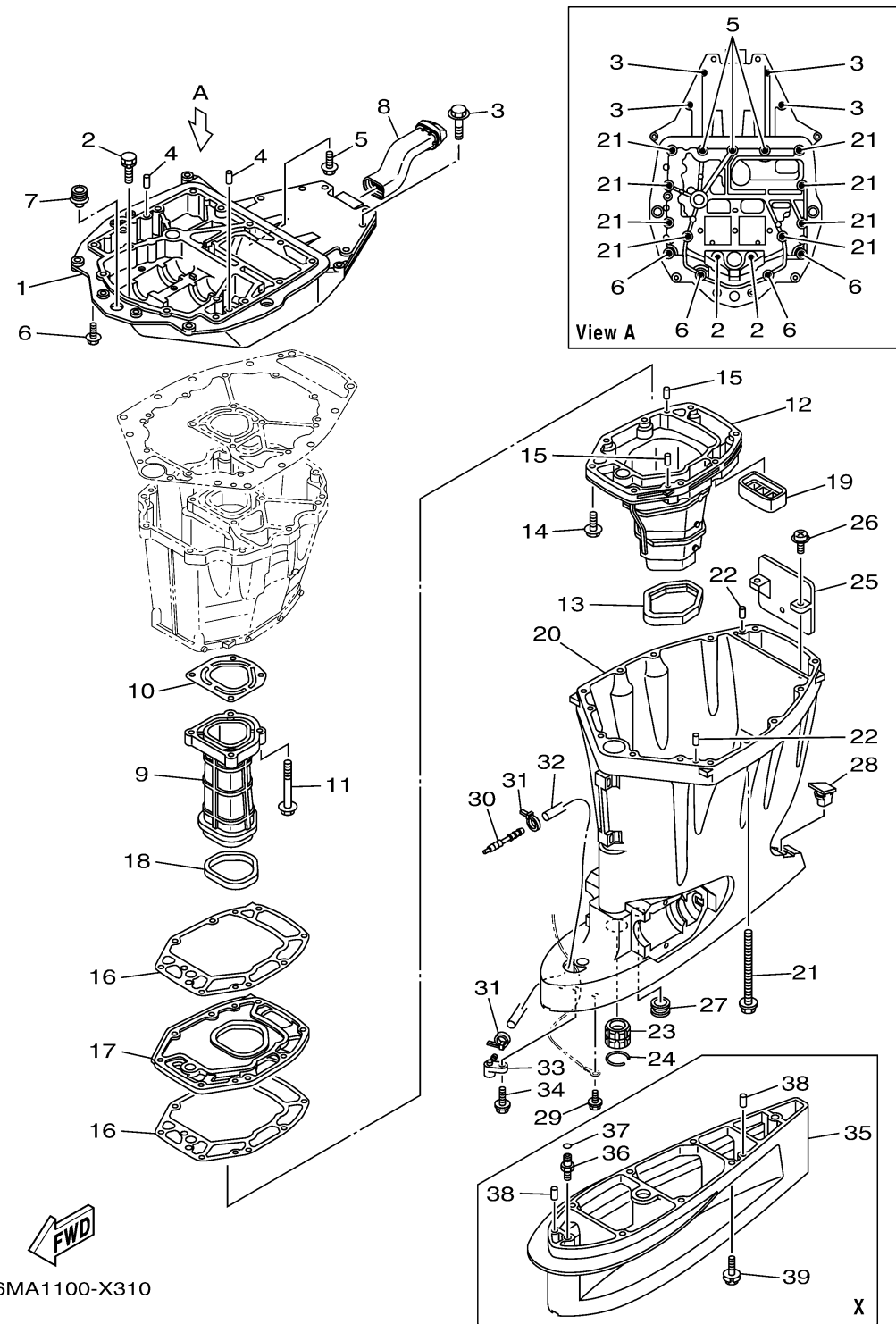

# UPPER CASING

Ref No.	Part Number	Description	Qty	Remarks
20	63P-45111-00-8D	CASING, UPPER	1	GRAY
20	63P-45111-00-CJ	CASING, UPPER	0	WARM WHITE
21	90119-10007-00	BOLT, WITH WASHER	8	
22	93608-16M16-00	PIN, DOWEL	2	
23	6E5-45318-00-00	BUSHING, DRIVE SHAFT	1	
24	93420-36M01-00	CIRCLIP	1	
25	69J-14624-01-00	COVER, EXHAUST	1	
26	97980-06216-00	SCREW, WITH WASHER	2	
27	6E5-44366-01-00	.DAMPER, WATER SEAL 2	1	
28	6C5-45155-02-00	CAP	1	
29	95D95-06010-00	BOLT, FLANGE DEEP RECESS	1	
30	6E5-83558-00-00	END, NIPPLE	1	
31	90465-11M10-00	CLAMP	2	
32	90445-070F1-00	HOSE (L950)	1	
33	63P-45379-00-00	NIPPLE, HOSE	1	
34	90119-06287-00	BOLT, WITH WASHER	1	
35	63P-45211-00-CE	EXTENSION	0	WHITE, X(25.2")
35	63P-45211-00-8D	EXTENSION	0	GRAY, X(25.2")
35	63P-45211-00-CJ	EXTENSION	0	WARM WHITE, X(25.2")
36	63P-45378-00-00	NIPPLE, HOSE	0	X(25.2")

CONTINUED ON NEXT FRAME >

# UPPER CASING

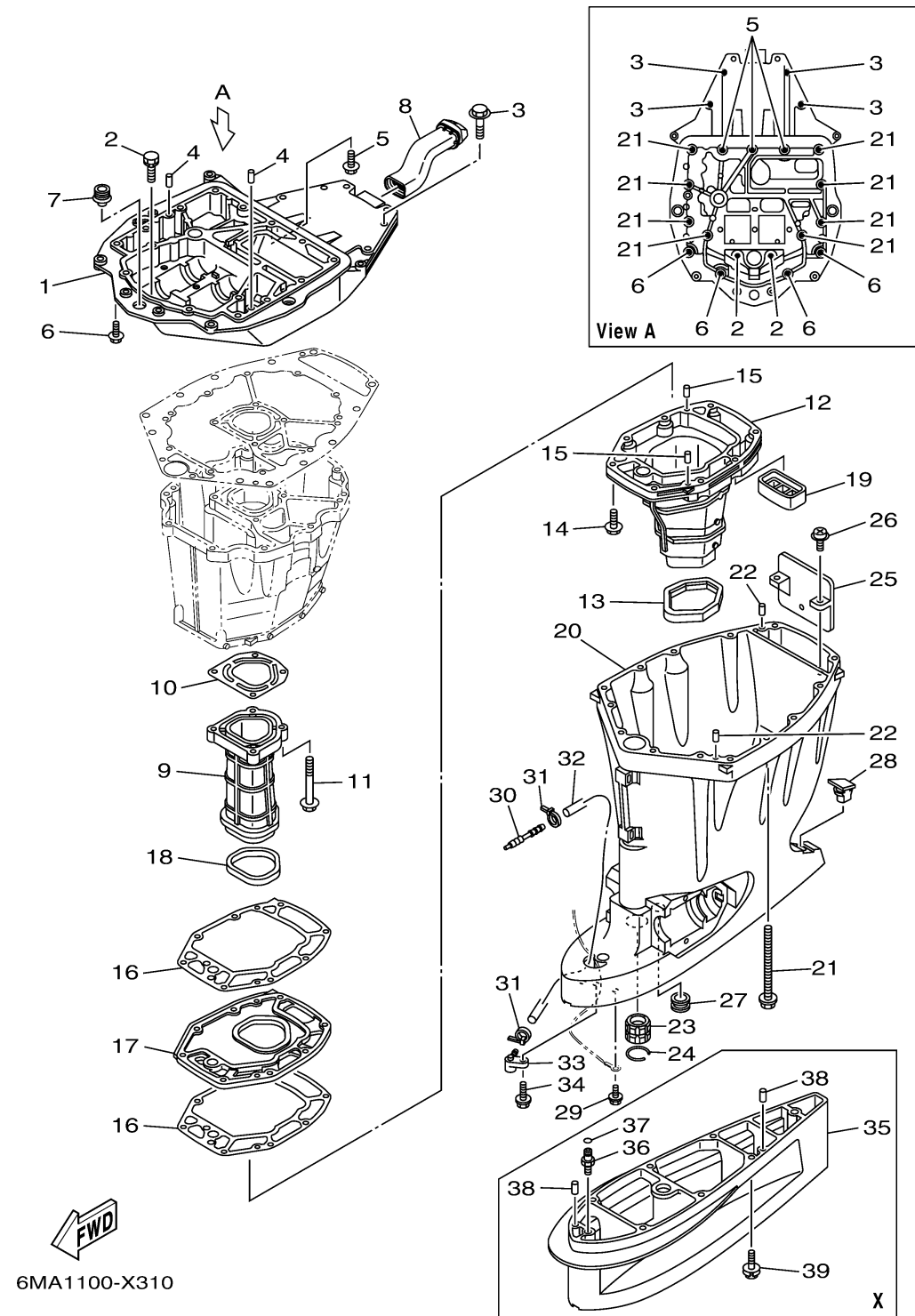

Ref No.	Part Number	Description	Qty	Remarks
37	93210-07003-00	O-RING	0	X(25.2")
38	93608-16M16-00	PIN, DOWEL	0	X(25.2")
39	97E95-10645-00	BOLT, HEXAGON W/W DEEP RECESS	0	X(25.2")