

ELECTRICAL 2

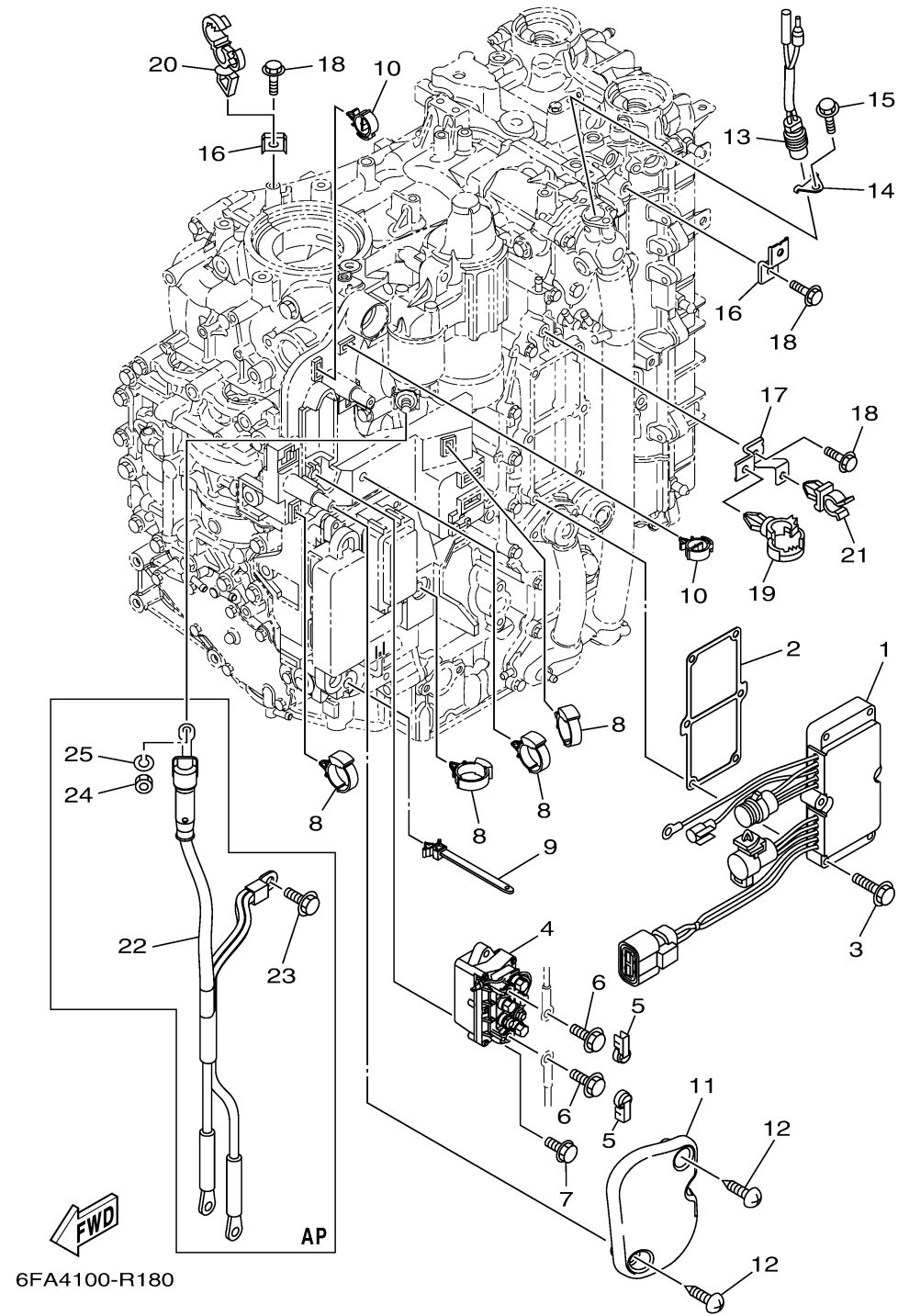

Ref No.	Part Number	Description	Qty	Remarks
1	6DA-81960-10-00	RECTIFIER & REGULATOR ASSY	1	
2	6DA-81975-01-00	PLATE, RECTIFIER FITTING	1	
3	97E95-06535-00	BOLT, HEXAGON W/W DEEP RECESS	6	
4	63P-W8195-00-00	RELAY ASSY	1	
5	6P2-8183X-00-00	CAP, TERMINAL	2	
6	97E95-06610-00	BOLT, HEXAGON W/W DEEP RECESS	2	
7	97E95-06520-00	BOLT, HEXAGON W/W DEEP RECESS	2	
8	90464-12183-00	CLAMP	4	
9	90464-12089-00	CLAMP	1	
10	90464-18246-00	CLAMP	2	
11	6DA-81942-01-00	COVER	1	
12	90169-05M00-00	SCREW, TRUSS HEAD TAPPING	2	
13	6P2-82560-01-00	THERMO SWITCH ASSY	1	
14	6E9-82588-00-00	PLATE	1	
15	95D95-06012-00	BOLT, FLANGE DEEP RECESS	1	
16	6DA-82388-00-00	PLATE	2	
17	6DA-82389-00-00	PLATE 2	1	
18	95D95-06016-00	BOLT, FLANGE DEEP RECESS	3	
19	90464-20181-00	CLAMP	1	
20	90464-13249-00	CLAMP	1	

CONTINUED ON NEXT FRAME >

ELECTRICAL 2

Ref No.	Part Number	Description	Qty	Remarks
21	90464-09008-00	CLAMP	1	
22	6DA-82105-02-00	BATTERY CABLE	1	AP
23	95D95-08016-00	BOLT, FLANGE DEEP RECESS	1	AP
24	95333-08600-00	NUT	1	AP
25	92903-08100-00	WASHER, SPRING	1	AP

