

CYLINDER CRANKCASE 1

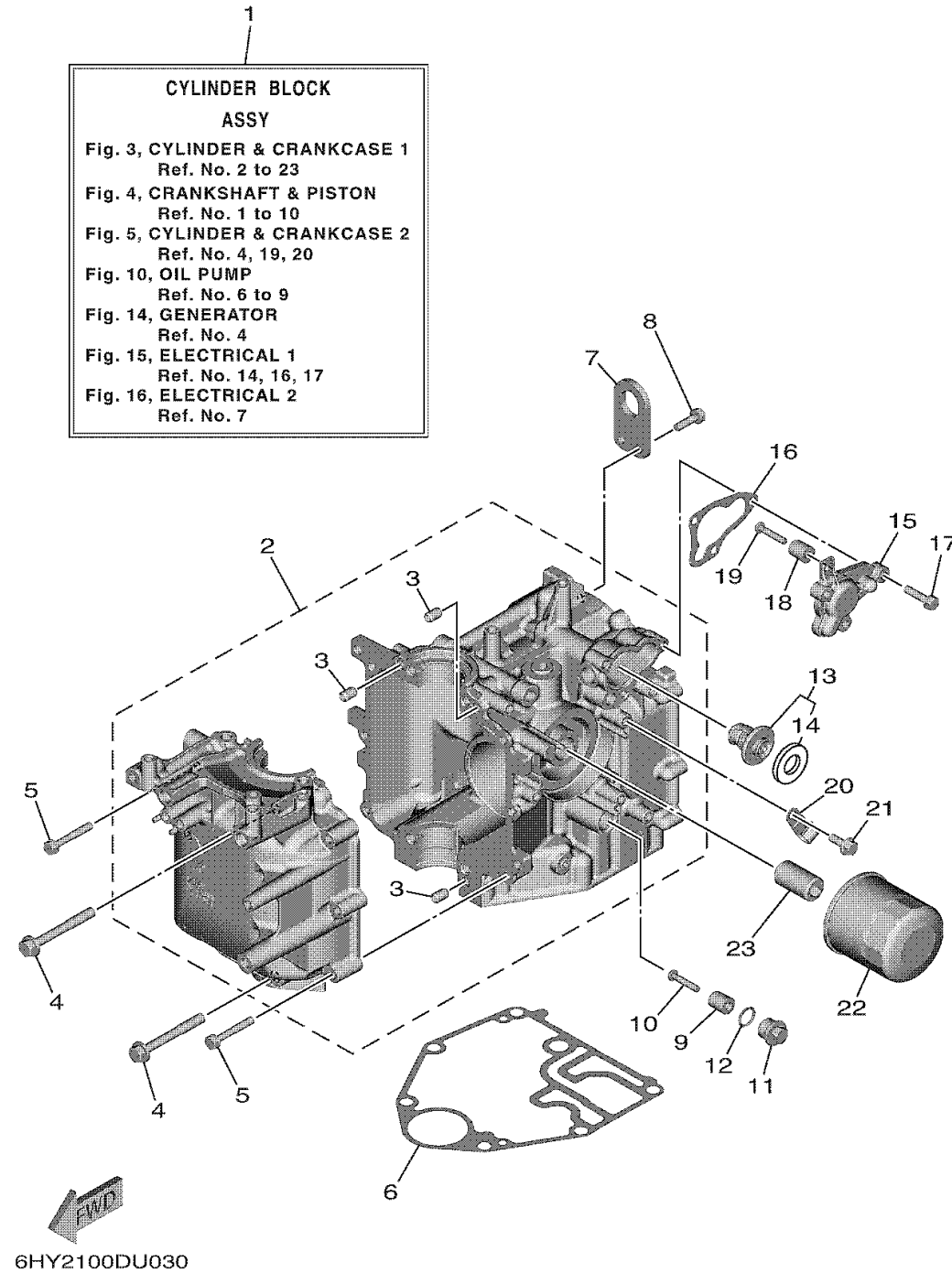

Ref No.	Part Number	Description	Qty	Remarks
1	6FM-W009B-02-1S	CYLINDER BLOCK ASSY	1	
2	6FM-15100-01-00	CRANKCASE ASSY	1	
3	99530-08012-00	. PIN, DOWEL	3	
4	90119-08093-00	BOLT, WITH WASHER	4	
5	97513-06540-00	BOLT, WITH WASHER	6	
6	6FM-11351-01-00	.GASKET, CYLINDER	1	
7	6FM-11119-00-00	HANGER, ENGINE	1	
8	90105-06M07-00	BOLT, FLANGE	2	
9	6G8-11325-00-00	ANODE	1	
10	98980-05025-00	SCREW, BIND	1	
11	6G8-11197-B0-00	PLUG, BLIND	1	
12	93210-13M63-00	.O-RING	1	
13	6FM-12411-00-00	THERMOSTAT	1	
14	6FM-12412-00-00	.SEAL, THERMOSTAT	1	
15	6FM-12413-00-1S	COVER, THERMOSTAT	1	
16	6FM-12414-00-00	.GASKET, COVER	1	
17	90119-06MA3-00	BOLT, WITH WASHER	3	
18	6G8-11325-00-00	ANODE	1	
19	98980-05025-00	SCREW, BIND	1	
20	90465-08M83-00	CLAMP	1	

CONTINUED ON NEXT FRAME >

CYLINDER CRANKCASE 1

Ref No.	Part Number	Description	Qty	Remarks
21	95D95-06016-00	BOLT, FLANGE DEEP RECESS	1	
22	5GH-13440-90-00	ELEMENT ASSY, OIL CLEANER	1	
23	6C5-12858-A0-00	BOLT, UNION	1	

