

# CYLINDER CRANKCASE 1

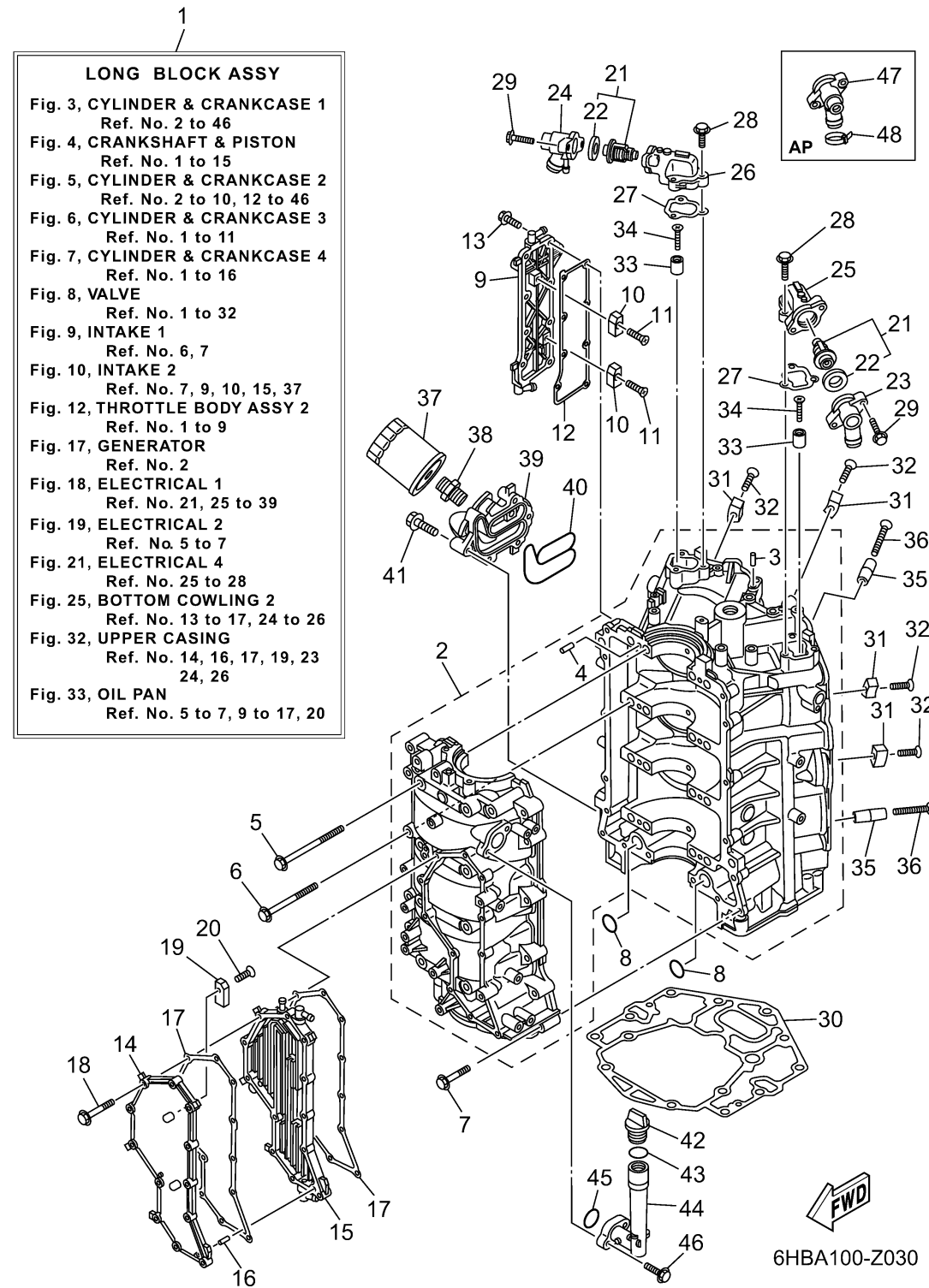

Ref No.	Part Number	Description	Qty	Remarks
1	6KA-11000-01-00	LONG BLOCK ASSY	1	
2	6CE-15100-10-00	CRANKCASE ASSY	1	
3	93606-12019-00	.PIN, DOWEL	3	
4	93606-12019-00	.PIN, DOWEL	8	
5	6CB-15187-00-00	BOLT	8	
6	6CB-15481-00-00	BOLT 1	8	
7	90105-08175-00	BOLT, FLANGE	16	
8	93210-26658-00	.O-RING	2	
9	6CE-1131C-00-9S	COVER, JOINT	1	
10	63P-11325-01-00	ANODE	2	
11	90151-06M02-00	SCREW, COUNTERSUNK	2	
12	6ML-1131B-00-00	.GASKET, COVER	1	
13	90105-06M07-00	.BOLT, FLANGE	8	
14	6CE-15411-00-9S	COVER, CRANKCASE 1	1	
15	6CE-15421-10-9S	COVER, CRANKCASE 2	1	
16	91690-40010-00	PIN, SPRING	1	
17	6CB-15451-01-00	.GASKET, CRANKCASE COVER 1	2	
18	90105-06151-00	BOLT, FLANGE	12	
19	63P-11325-01-00	ANODE	2	
20	90151-06M02-00	SCREW, COUNTERSUNK	2	

CONTINUED ON NEXT FRAME >

# CYLINDER CRANKCASE 1

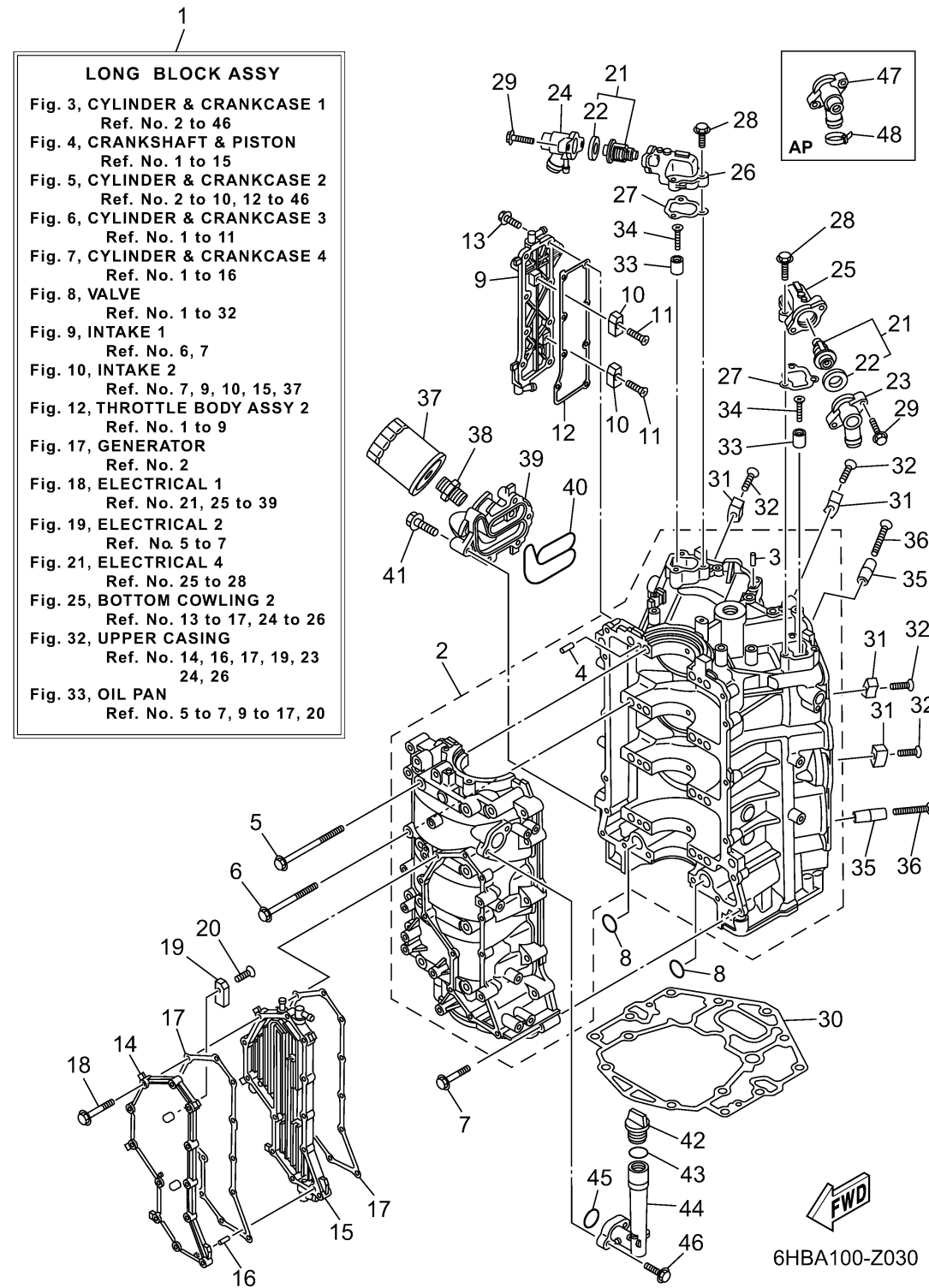

Ref No.	Part Number	Description	Qty	Remarks
21	6CE-12411-00-00	THERMOSTAT	2	
22	67F-12412-00-00	.SEAL, THERMOSTAT	1	
23	6CE-12413-B0-9S	COVER, THERMOSTAT	1	
24	6CE-12413-A0-9S	COVER, THERMOSTAT	1	
25	6CB-12422-10-9S	COVER, HOUSING	1	
26	6CB-12422-20-9S	COVER, HOUSING	1	
27	6CB-12427-11-00	.GASKET, HOUSING COVER 1	2	
28	95027-06025-00	BOLT, FLANGE	6	
29	90105-06037-00	BOLT, FLANGE	4	
30	6KA-11351-00-00	.GASKET, CYLINDER	1	
31	6AW-1132P-00-00	ANODE 5	4	
32	98780-06530-00	SCREW, FLAT HEAD	4	
33	68T-11325-00-00	ANODE	2	
34	90151-05M05-00	SCREW, COUNTERSUNK	2	
35	6AW-1132N-01-00	ANODE 4	2	
36	98780-06550-00	SCREW, FLAT HEAD	2	
37	N26-13440-04-00	ELEMENT ASSY, OIL CLEANER	1	
38	90401-19001-00	BOLT, UNION	1	
39	6CE-13446-10-9S	CONNECTOR	1	
40	6CB-13477-00-00	.GASKET	1	

CONTINUED ON NEXT FRAME >

# CYLINDER CRANKCASE 1

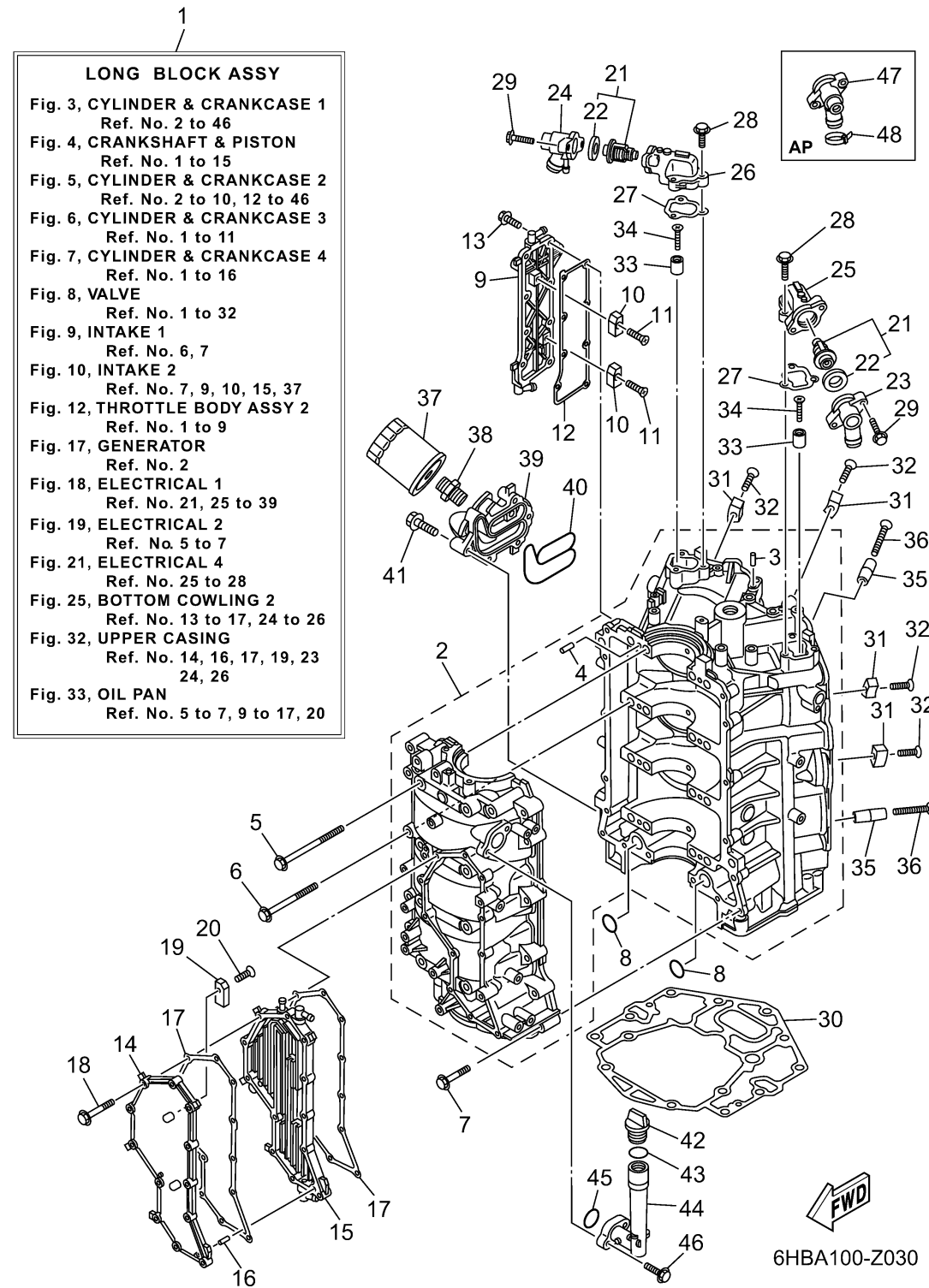

Ref No.	Part Number	Description	Qty	Remarks
41	90105-06151-00	BOLT, FLANGE	5	
42	6G8-15363-00-00	PLUG, OIL	1	
43	93210-24M79-00	.O-RING	1	
44	6CB-15319-00-00	JOINT	1	
45	93210-27370-00	.O-RING	1	
46	90105-06037-00	BOLT, FLANGE	2	
47	6CE-12413-H0-9S	COVER, THERMOSTAT	1	AP WATER TEMP SENSOR
48	90465-11M59-00	CLAMP	1	AP WATER TEMP SENSOR