

ELECTRICAL 4

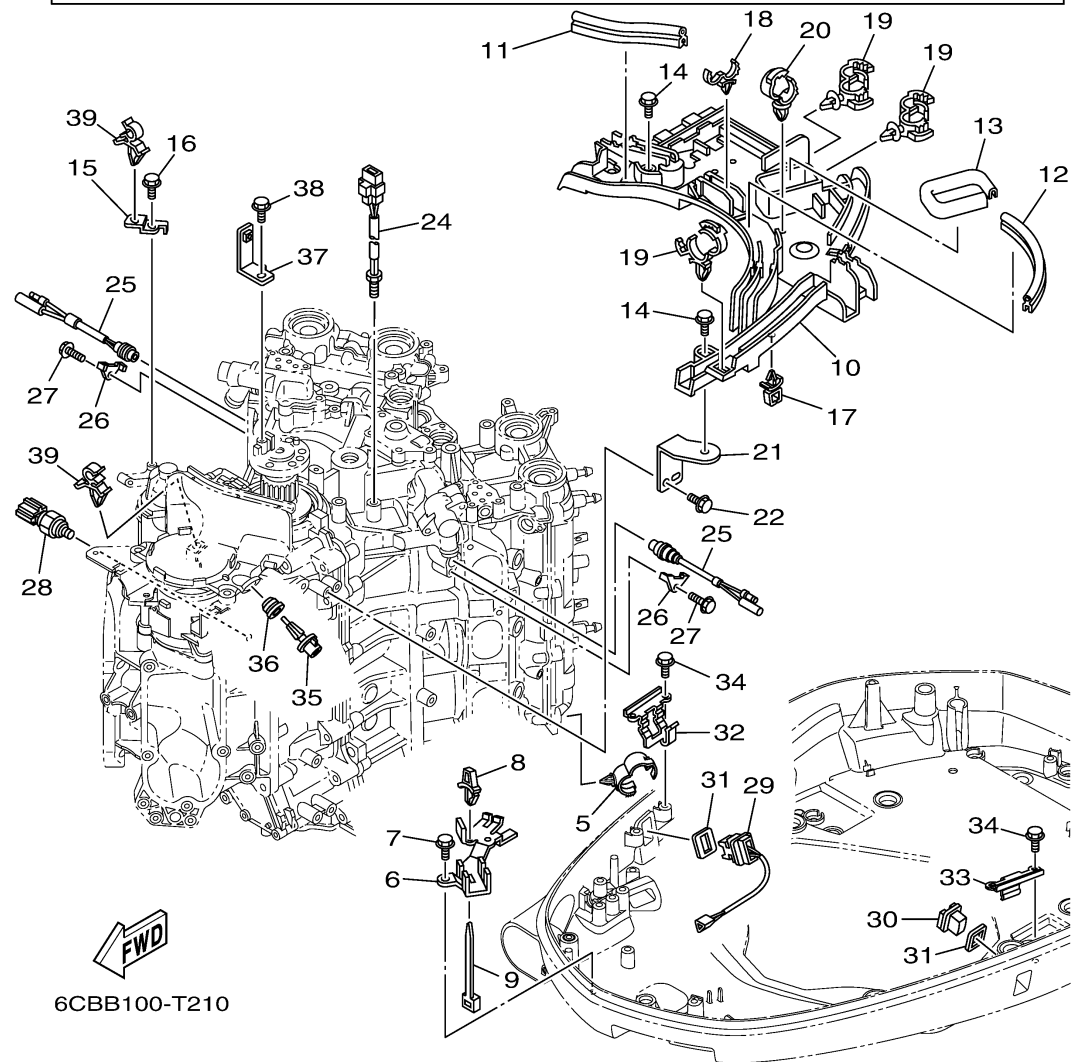
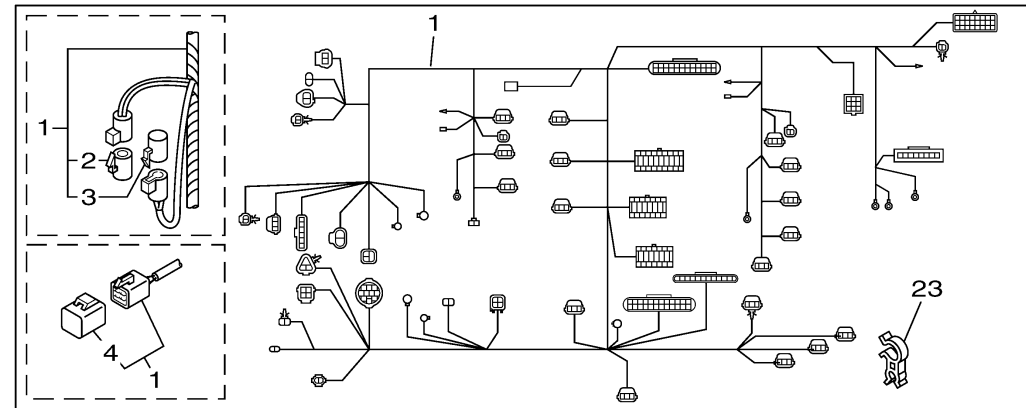

Ref No.	Part Number	Description	Qty	Remarks
1	6CB-82590-13-00	WIRE HARNESS ASSY	1	
2	6P2-82582-00-00	..CAP 1 (FEMALE)	1	
3	6P2-82582-10-00	..CAP 1 (MALE)	1	
4	6Y8-82582-11-00	..CAP 1 (4PIN)	1	
5	90464-20181-00	CLAMP	4	
6	6CB-82594-00-00	CLAMP	1	
7	95D95-06012-00	BOLT, FLANGE DEEP RECESS	2	
8	90464-06001-00	CLAMP	1	
9	90465-13M24-00	CLAMP	1	
10	6CB-82589-10-00	PROTECTOR, WIRE HARNESS	1	
11	6AH-42617-00-00	DAMPER, FORM	1	
12	6CB-42617-00-00	DAMPER, FORM	1	
13	6CB-42629-00-00	SEAL	1	
14	95D95-06020-00	BOLT, FLANGE DEEP RECESS	4	
15	6CB-8132G-00-00	PLATE	1	
16	95D95-06016-00	BOLT, FLANGE DEEP RECESS	1	
17	90464-11121-00	CLAMP	1	
18	90464-18246-00	CLAMP	1	
19	90464-12183-00	CLAMP	4	
20	90464-20181-00	CLAMP	2	

CONTINUED ON NEXT FRAME >

ELECTRICAL 4

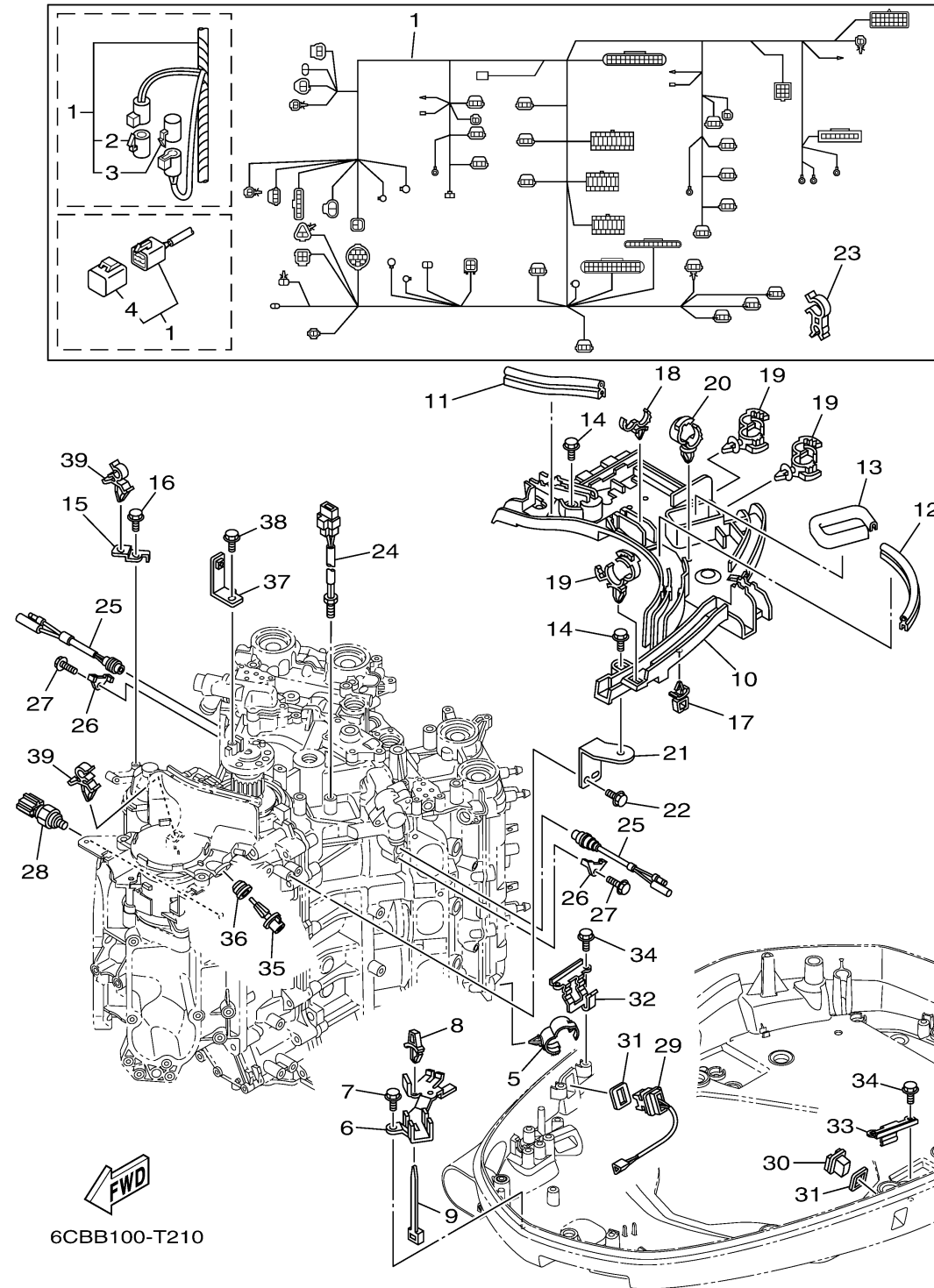

Ref No.	Part Number	Description	Qty	Remarks
21	6CB-82388-00-00	PLATE	1	
22	95D95-06016-00	BOLT, FLANGE DEEP RECESS	2	
23	90464-23001-00	CLAMP	1	
24	6CB-85790-00-00	THERMOSENSOR ASSY	1	
25	6P2-82560-01-00	THERMO SWITCH ASSY	2	
26	6E9-82588-00-00	PLATE	2	
27	95D95-06012-00	BOLT, FLANGE DEEP RECESS	2	
28	6AW-83651-01-00	SENDER, OIL PRESSURE	1	
29	69J-82563-01-00	TRIM & TILT SWITCH ASSY	1	
30	69J-42723-01-00	COVER, BOTTOM	1	
31	69J-82587-01-00	GASKET	2	
32	63P-83614-01-00	BRACKET	1	
33	6DA-83614-00-00	BRACKET	1	
34	95D95-06012-00	BOLT, FLANGE DEEP RECESS	4	
35	63P-85886-00-00	SENSOR, AIR TEMPERATURE	1	
36	6CE-14435-00-00	GROMMET	1	
37	6CB-81952-10-00	HOLDER, RELAY	1	
38	95D95-06016-00	BOLT, FLANGE DEEP RECESS	1	
39	90464-09129-00	CLAMP	2	