

OIL PAN

Ref No.	Part Number	Description	Qty	Remarks
1	6CB-15311-01-00	OIL PAN	1	
2	97E75-08535-00	BOLT, HEXAGON W/W DEEP RECESS	10	
3	93608-16M16-00	PIN, DOWEL	2	
4	90340-14M06-00	PLUG, STRAIGHT SCREW	1	
5	90430-14M09-00	.GASKET	1	
6	6CB-13411-00-00	STRAINER, OIL	1	
7	6AW-13415-00-00	.SEAL, OIL STRAINER	1	
8	95812-06025-00	BOLT, FLANGE	3	
9	6CB-13300-00-00	OIL PUMP ASSY	1	
10	6CB-13329-00-00	.GASKET, PUMP COVER	1	
11	6AW-13119-00-00	.OIL SEAL	1	
12	69J-13631-00-00	.OIL SEAL	2	
13	6CB-11355-00-00	.SEAL, CYLINDER 1	1	
14	95D75-06040-00	BOLT, FLANGE DEEP RECESS	4	
15	93210-26658-00	.O-RING	2	
16	6CB-13490-00-00	RELIEF VALVE ASSY	1	
17	6CB-13473-00-00	.O-RING	1	
18	6CB-15362-00-00	PLUG, OIL LEVEL	1	
19	6CB-15377-00-00	GUIDE, INLET	1	
20	93210-19MJ3-00	.O-RING	1	

CONTINUED ON NEXT FRAME >

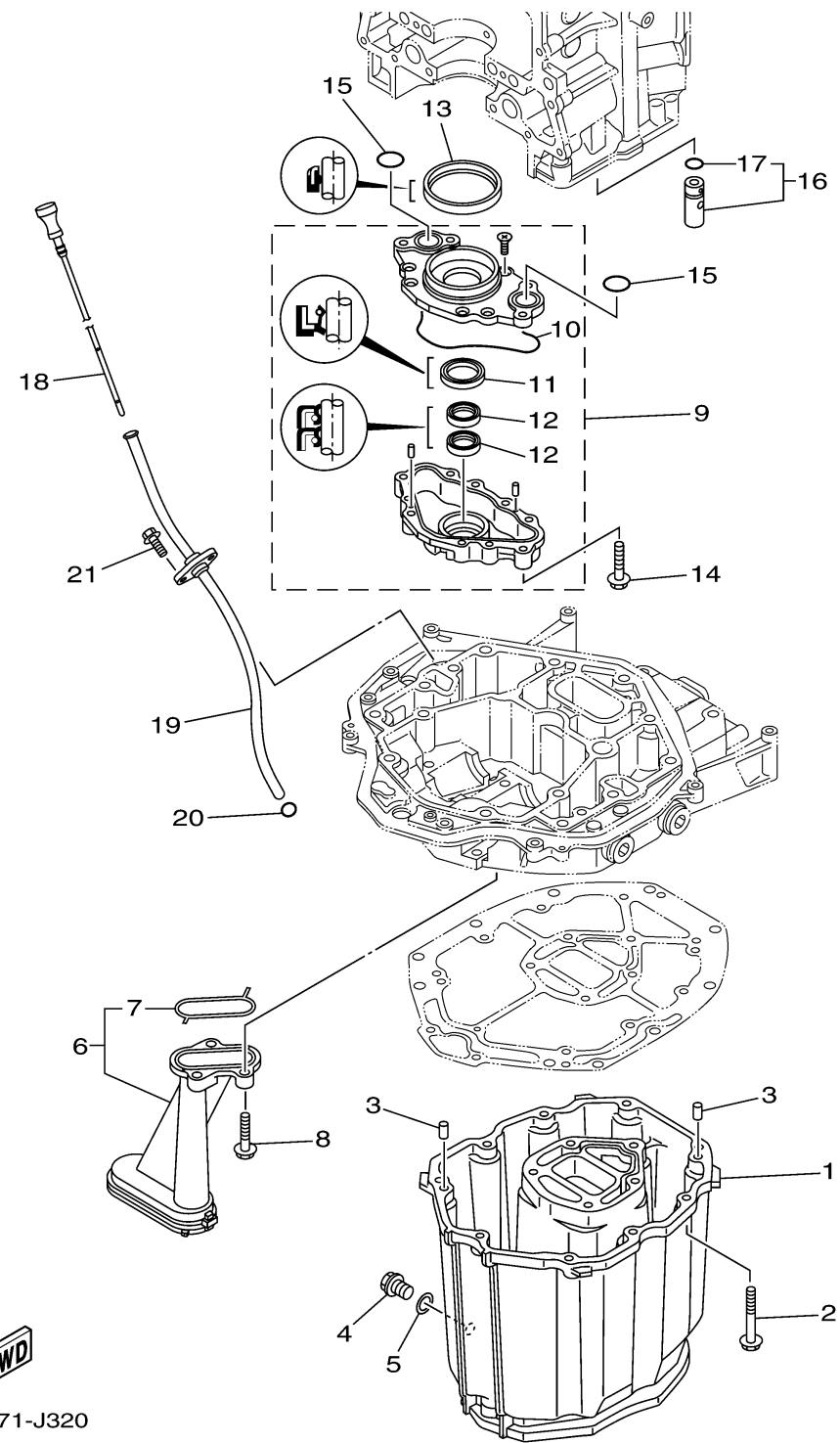

6CB1171-J320

OIL PAN

Ref No.	Part Number	Description	Qty	Remarks
21	95D95-06016-00	BOLT, FLANGE DEEP RECESS	2	

