

CONTROL

Ref No.	Part Number	Description	Qty	Remarks
1	6ML-4820A-00-00	ACTUATOR UNIT	1	
2	90386-08008-00	BUSH	1	
3	90119-08168-00	BOLT, WITH WASHER	4	
4	90201-12064-00	WASHER, PLATE	4	
5	90387-08104-00	COLLAR	4	
6	6CE-85564-00-00	GROMMET	8	
7	6CE-44142-20-00	JOINT	1	
8	6CE-42195-10-00	PIN, JOINT 1	1	
9	6CE-44122-20-00	BUSHING, SHIFT ROD LEVER	1	
10	90202-08M41-00	WASHER, PLATE	2	
11	90201-06068-00	WASHER, PLATE	1	
12	90185-06M07-00	NUT, SELF-LOCKING	1	
13	90468-18008-00	CLIP	1	
14	6CE-44117-10-00	BRACKET	1	
15	97E75-06525-00	BOLT, HEXAGON W/W DEEP RECESS	2	
16	6CE-44121-10-00	LEVER, SHIFT ROD	1	
17	90468-18008-00	CLIP	1	
18	6CE-44118-A0-00	BRACKET	1	
19	93604-07M13-00	PIN, DOWEL	2	
20	6JD-44120-01-00	HANDLE GEAR SHIFT ASSY	1	

CONTINUED ON NEXT FRAME >

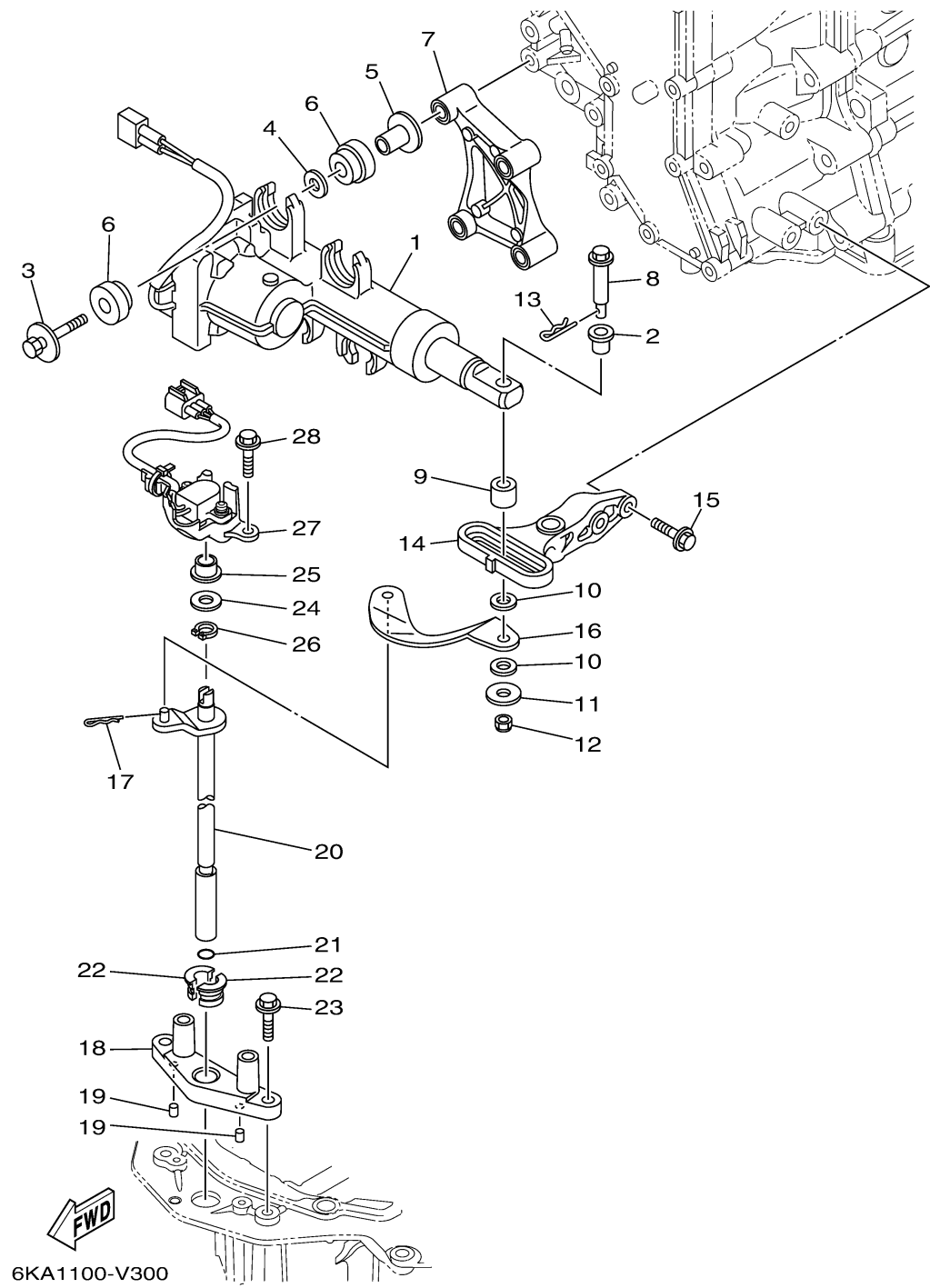

CONTROL

Ref No.	Part Number	Description	Qty	Remarks
21	93210-09165-00	O-RING	1	
22	90386-11001-00	BUSH	2	
23	95D75-06025-00	BOLT, FLANGE DEEP RECESS	2	
24	90201-11008-00	WASHER, PLATE	1	
25	90386-10001-00	BUSH	1	
26	93410-10082-00	CIRCLIP	1	
27	6CE-68303-00-00	SENSOR ASSY	1	
28	95D75-06025-00	BOLT, FLANGE DEEP RECESS	2	