

UPPER CASING

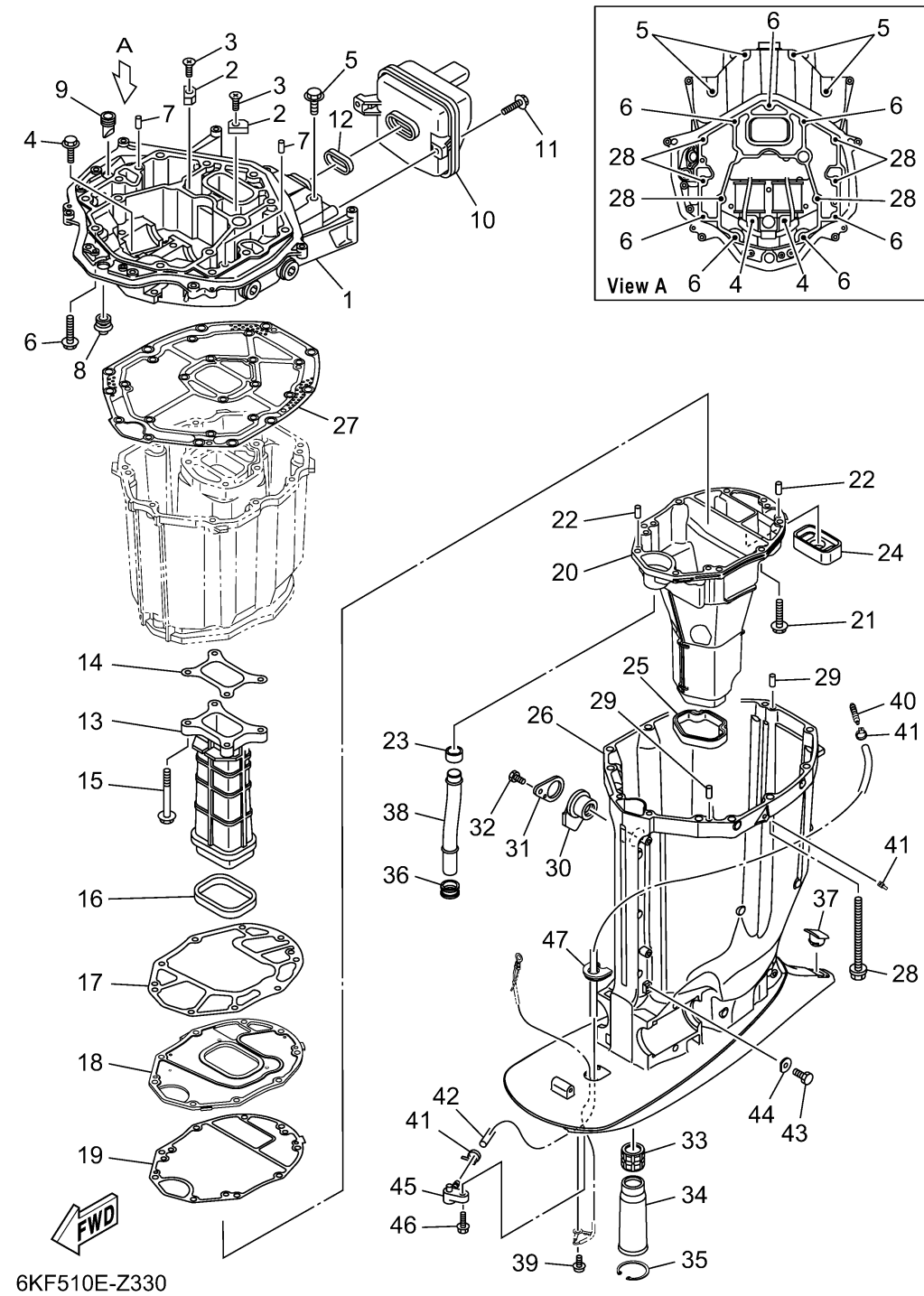

Ref No.	Part Number	Description	Qty	Remarks
1	6CE-41137-01-00	GUIDE, EXHAUST	1	
2	63P-11325-11-00	ANODE	2	
3	90151-06M02-00	SCREW, COUNTERSUNK	2	
4	90119-08182-00	BOLT, WITH WASHER	2	
5	97E75-10545-00	BOLT, HEXAGON W/W DEEP RECESS	4	
6	97E75-10535-00	BOLT, HEXAGON W/W DEEP RECESS	7	
7	93608-16M16-00	PIN, DOWEL	2	
8	6E5-42724-01-00	GROMMET	1	
9	61A-42717-00-00	RUBBER, SEAL 2	1	
10	6CB-14750-A0-00	SILENCER ASSY	1	
11	95D95-06020-00	BOLT, FLANGE DEEP RECESS	2	
12	6CB-14755-01-00	.GASKET, SILENCER	1	
13	6CB-41132-01-00	MANIFOLD, EXHAUST	1	
14	6CB-41134-00-00	.GASKET, EXHAUST MANIFOLD 2	1	
15	97E75-08560-00	BOLT, HEXAGON W/W DEEP RECESS	4	
16	6CB-41138-00-00	.SEAL, EXT. 1	1	
17	6CB-41135-00-00	.GASKET, EXHAUST MANIFOLD	1	
18	6KA-45181-00-00	PLATE	1	
19	6CE-41136-00-00	.GASKET, EXHAUST MANIFOLD 4	1	
20	6KA-14711-00-00	MUFFLER 1	1	

CONTINUED ON NEXT FRAME >

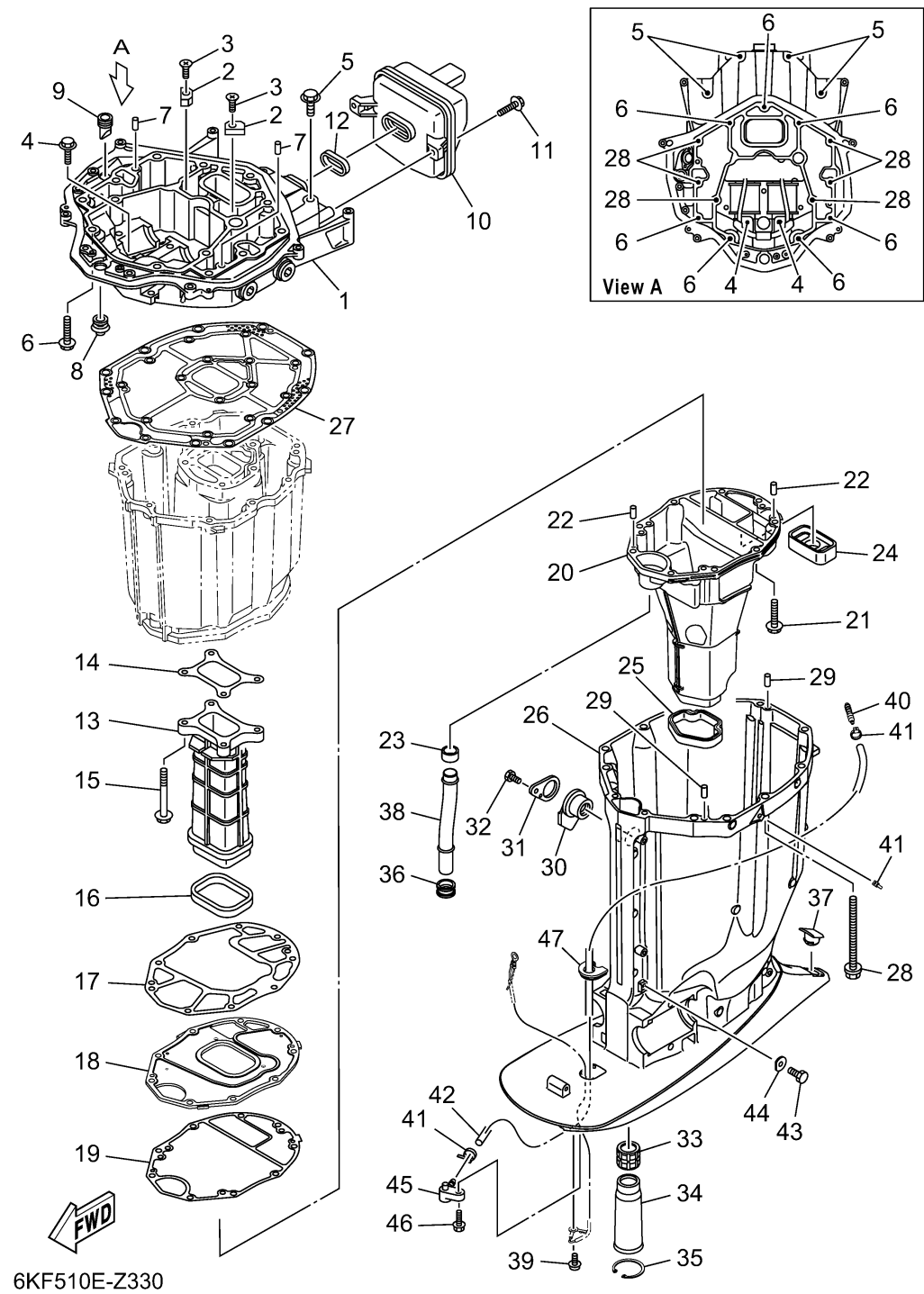

UPPER CASING

Ref No.	Part Number	Description	Qty	Remarks
21	97E75-08535-00	BOLT, HEXAGON W/W DEEP RECESS	9	
22	93606-19M23-00	PIN, DOWEL	2	
23	6AW-44365-01-00	.DAMPER, WATER SEAL 1	1	
24	6CE-45127-00-00	.SEAL	1	
25	6CE-45123-00-00	.GASKET, MUFFLER	1	
26	6KA-45111-01-8D	CASING, UPPER	1	GRAY
26	6KA-45111-01-CE	CASING, UPPER	0	WHITE
27	6CB-45113-10-00	.GASKET, UPPER CASING	1	
28	90119-10007-00	BOLT, WITH WASHER	6	
29	93608-16M16-00	PIN, DOWEL	2	
30	6BB-15316-01-00	DAMPER 1	1	
31	6BB-45152-01-00	COVER, UPPER CASING 2	1	
32	97D95-06012-00	BOLT, HEXAGON DEEP RECESS	1	
33	69J-45318-01-00	BUSHING, DRIVE SHAFT	1	
34	6KA-46153-00-00	COLLAR, GUIDE	1	
35	93420-50093-00	CIRCLIP	1	
36	6AW-44366-01-00	.DAMPER, WATER SEAL 2	1	
37	61A-45155-01-00	CAP	1	
38	6CE-44361-00-00	TUBE, WATER 1	1	
39	95D95-06010-00	BOLT, FLANGE DEEP RECESS	1	

CONTINUED ON NEXT FRAME >

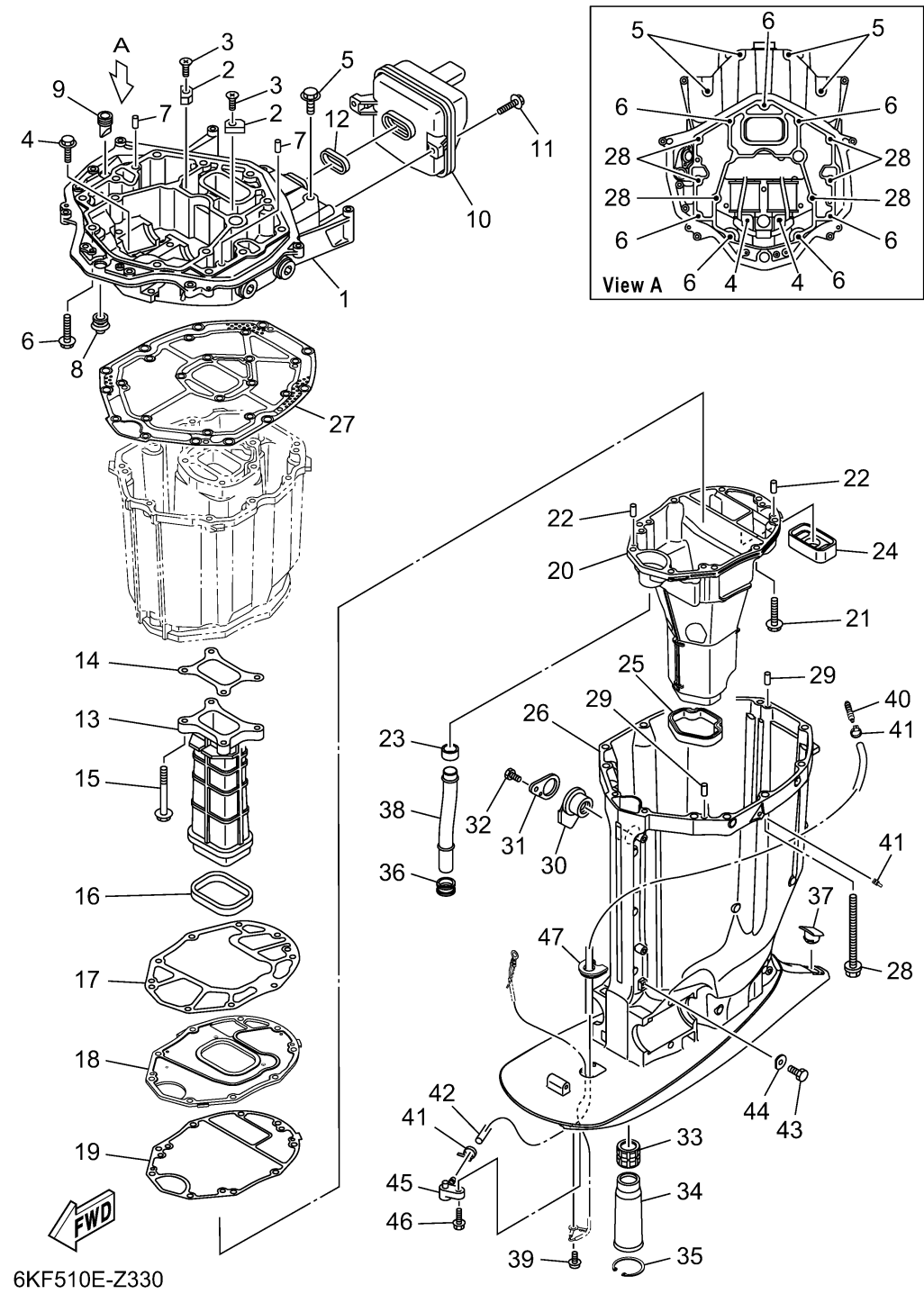

UPPER CASING

Ref No.	Part Number	Description	Qty	Remarks
40	6E5-83558-00-00	END, NIPPLE	1	
41	90465-11M10-00	CLAMP	3	
42	6KF-46894-00-00	HOSE	1	
43	97D95-06010-00	BOLT, HEXAGON DEEP RECESS	1	
44	90201-06M02-00	WASHER, PLATE	1	
45	63P-45379-00-00	NIPPLE, HOSE	1	
46	90119-06287-00	BOLT, WITH WASHER	1	
47	6KA-44521-00-00	.SEAL	1	