

CYLINDER CRANKCASE 1

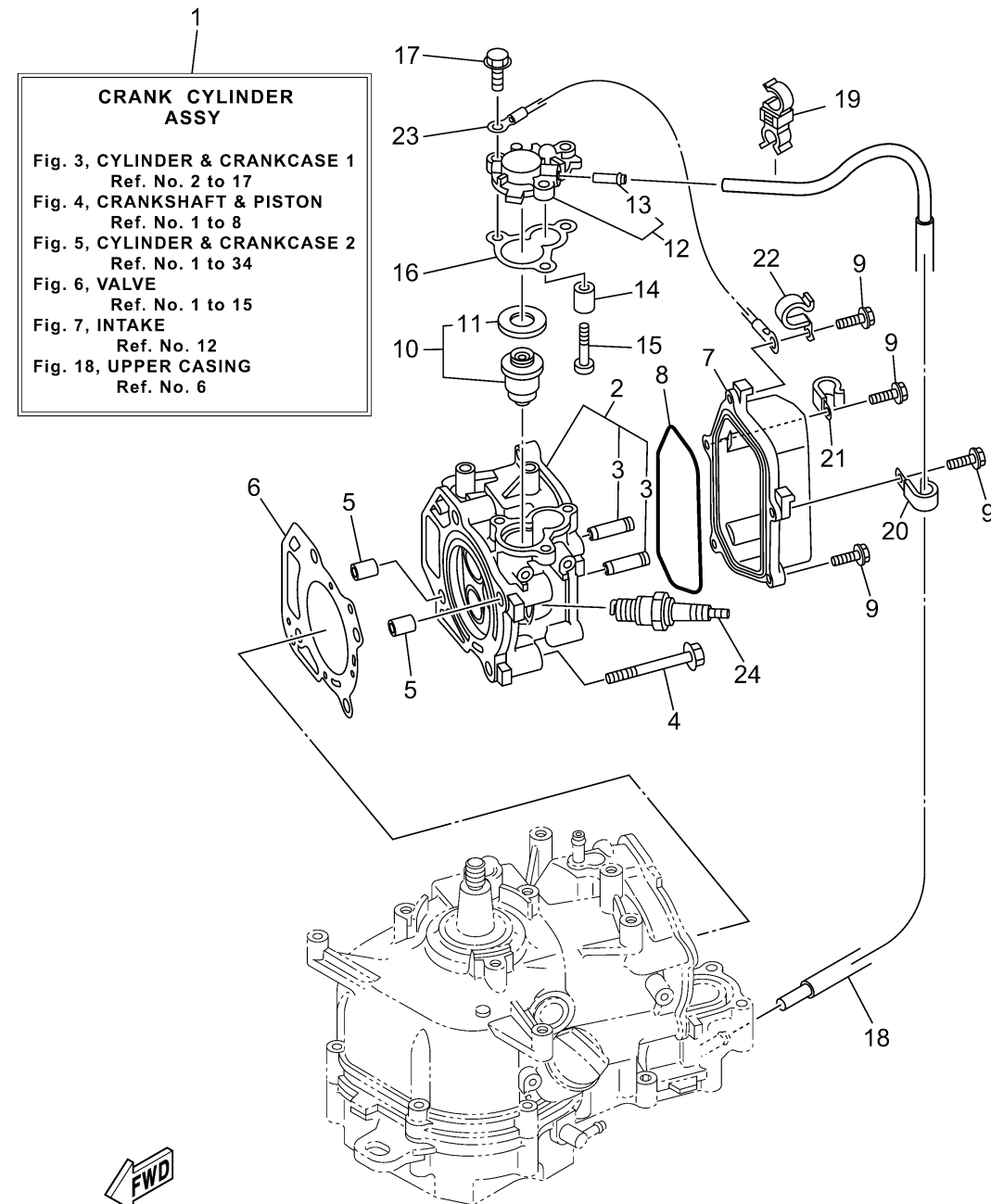

Ref No.	Part Number	Description	Qty	Remarks
1	6EE-W0090-00-1S	CRANK CYLINDER ASSY	1	
2	6EE-11111-00-1S	HEAD, CYLINDER 1	1	
3	6EE-82519-00-00	WIRE, EARTH LEAD	1	
3	67D-11133-10-00	. .GUIDE, VALVE 1	2	
4	90105-08M36-00	BOLT, FLANGE	4	
5	99530-10114-00	PIN, DOWEL	2	
6	6BX-11181-00-00	.GASKET, CYLINDER HEAD 1	1	
7	6EE-11191-00-00	COVER, CYLINDER HEAD 1	1	
8	6BX-11356-00-00	.SEAL, CYLINDER 2	1	
9	97E95-06520-00	BOLT, HEXAGON W/W DEEP RECESS	5	
10	66M-12411-01-00	THERMOSTAT	1	
11	688-12412-00-00	. .SEAL, THERMOSTAT	1	
12	6EE-12413-00-1S	COVER, THERMOSTAT	1	
13	650-24378-00-00	. .PIPE, JOINT 4	1	
14	6G8-11325-00-00	ANODE	1	
15	98980-05025-00	SCREW, BIND	1	
16	67D-12414-A0-00	.GASKET, COVER	1	
17	90119-06MA2-00	BOLT, WITH WASHER	3	
18	90445-09136-00	HOSE	1	
19	90464-09021-00	CLAMP	1	

CONTINUED ON NEXT FRAME >

CYLINDER CRANKCASE 1

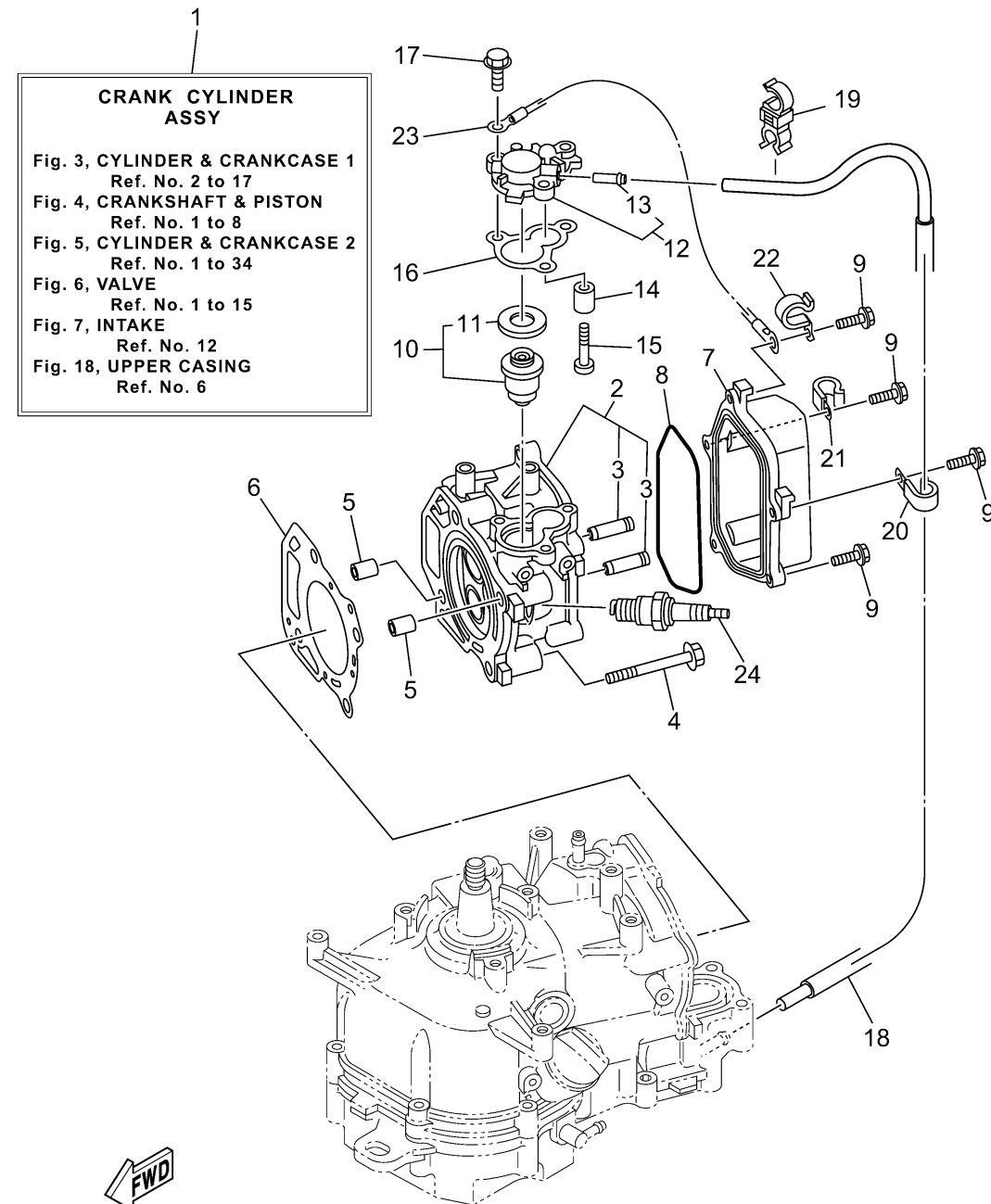

6ECC100-Z030

Ref No.	Part Number	Description	Qty	Remarks
20	90465-06M86-00	CLAMP	1	
21	90465-06M86-00	CLAMP	1	
22	90465-08371-00	CLAMP	1	
23	CR6-HSB00-00-00	PLUG, SPARK (NGK CR6HSB)	1	