

OPTIONAL PARTS 2

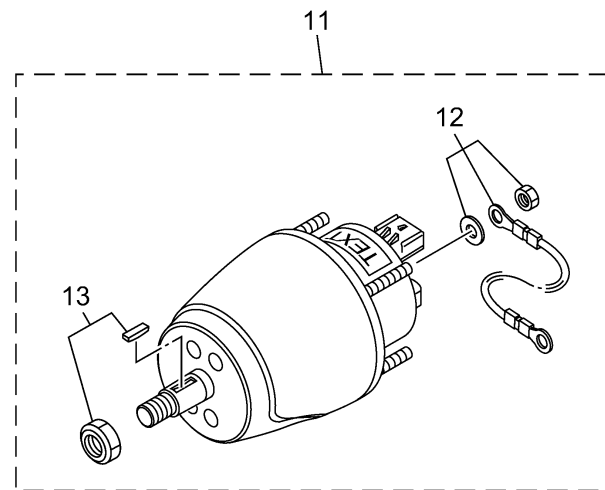
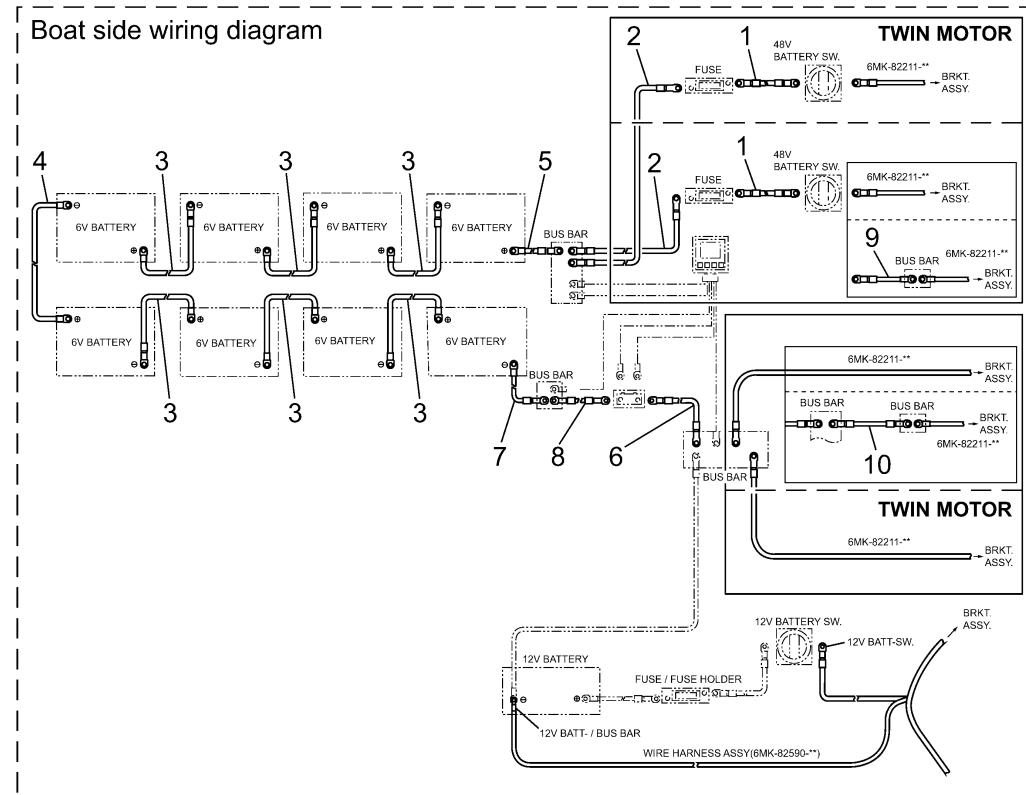

6MK2100-Z170

Ref No.	Part Number	Description	Qty	Remarks
1	6MK-82223-00-00	WIRE, HIGH VOLTAGE PLUS LEAD 2	1	SINGLE MOTOR
1	6MK-82223-00-00	WIRE, HIGH VOLTAGE PLUS LEAD 2	2	TWIN MOTOR
2	6MK-82223-10-00	WIRE, HIGH VOLTAGE PLUS LEAD 2	1	SINGLE MOTOR
2	6MK-82223-10-00	WIRE, HIGH VOLTAGE PLUS LEAD 2	2	TWIN MOTOR
3	6MK-82212-30-00	WIRE, HIGH VOLTAGE LEAD 2	6	SINGLE MOTOR
3	6MK-82212-00-00	WIRE, HIGH VOLTAGE LEAD 2	6	TWIN MOTOR
4	6MK-82212-40-00	WIRE, HIGH VOLTAGE LEAD 2	1	SINGLE MOTOR
4	6MK-82212-10-00	WIRE, HIGH VOLTAGE LEAD 2	1	TWIN MOTOR
5	6MK-82223-50-00	WIRE, HIGH VOLTAGE PLUS LEAD 2	1	SINGLE MOTOR
5	6MK-82223-30-00	WIRE, HIGH VOLTAGE PLUS LEAD 2	1	TWIN MOTOR
6	6MK-82224-00-00	WIRE, HIGH VOLTAGE MINUS LEAD2	1	SINGLE MOTOR
6	6MK-82224-30-00	WIRE, HIGH VOLTAGE MINUS LEAD2	1	TWIN MOTOR
7	6MK-82224-10-00	WIRE, HIGH VOLTAGE MINUS LEAD2	1	SINGLE MOTOR
7	6MK-82224-50-00	WIRE, HIGH VOLTAGE MINUS LEAD2	1	TWIN MOTOR
8	6MK-82224-G0-00	WIRE, HIGH VOLTAGE MINUS LEAD2	1	SINGLE MOTOR
8	6MK-82224-40-00	WIRE, HIGH VOLTAGE MINUS LEAD2	1	TWIN MOTOR
9	6MK-82223-20-00	WIRE, HIGH VOLTAGE PLUS LEAD 2	1	UR
9	6MK-82223-60-00	WIRE, HIGH VOLTAGE PLUS LEAD 2	1	UR
9	6MK-82223-70-00	WIRE, HIGH VOLTAGE PLUS LEAD 2	1	UR
10	6MK-82224-20-00	WIRE, HIGH VOLTAGE MINUS LEAD2	1	UR

CONTINUED ON NEXT FRAME >

OPTIONAL PARTS 2

Ref No.	Part Number	Description	Qty	Remarks
10	6MK-82224-60-00	WIRE, HIGH VOLTAGE MINUS LEAD2	1	UR
10	6MK-82224-70-00	WIRE, HIGH VOLTAGE MINUS LEAD2	1	UR
11	6JM-615A0-10-00	HELM ASSY.	1	
12	6X9-42409-00-00	. .REPAIR KIT, 8	1	
13	6X9-4240A-00-00	. .REPAIR KIT, 9	1	

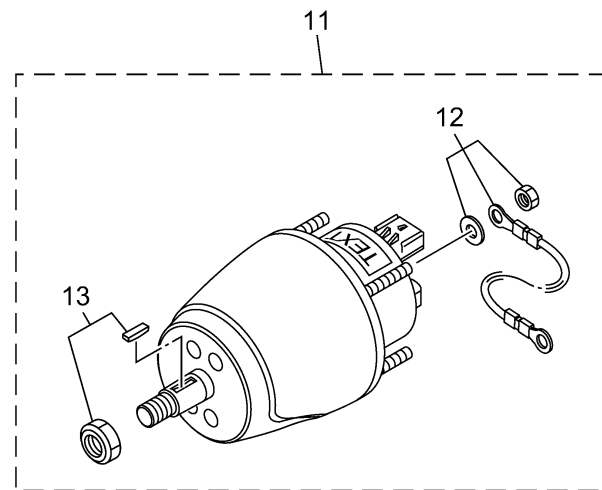
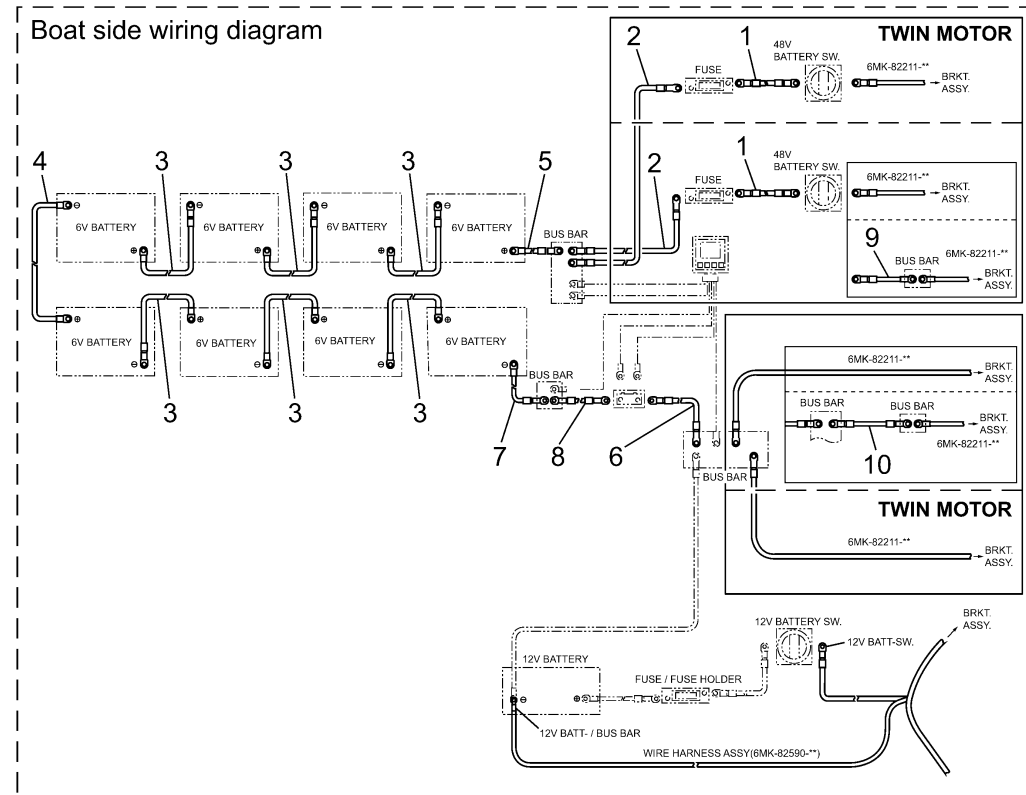

6MK2100-Z170