

# LOWER CASING DRIVE 1

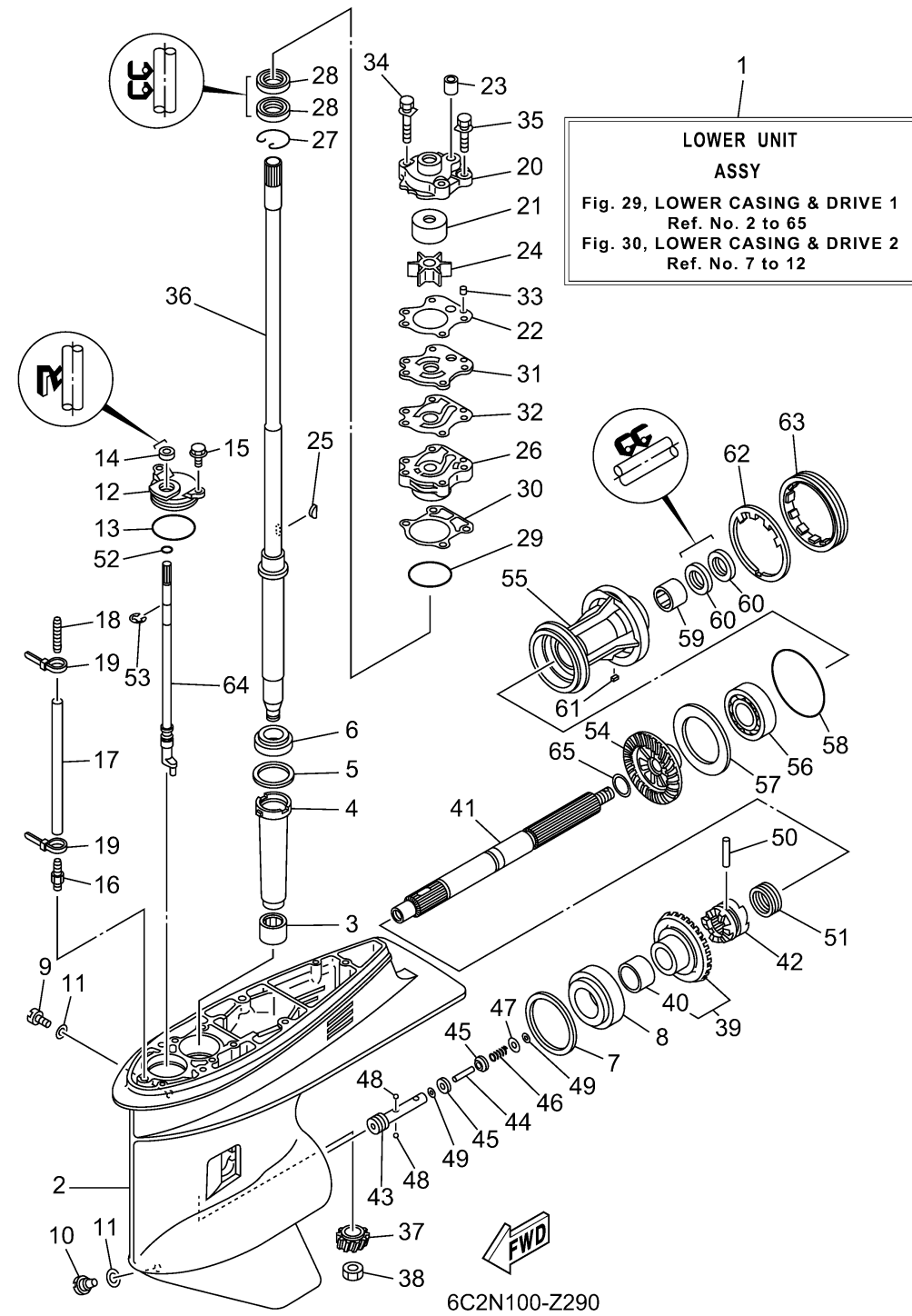

Ref No.	Part Number	Description	Qty	Remarks
1	68S-45300-34-8D	LOWER UNIT ASSY	1	L(20.9")
2	67F-45301-00-8D	CASING, LOWER	1	
3	93315-52563-00	BEARING	1	
4	688-45536-01-00	SLEEVE, DRIVE SHAFT	1	
5	688-45587-01-00	SHIM (T:0.10MM)	1	UR
5	688-45587-10-00	SHIM (T:0.12MM)	1	UR
5	688-45587-20-00	SHIM (T:0.15MM)	1	UR
5	688-45587-30-00	SHIM (T:0.18MM)	1	UR
5	688-45587-40-00	SHIM (T:0.30MM)	1	UR
5	688-45587-50-00	SHIM (T:0.40MM)	1	UR
5	688-45587-60-00	SHIM (T:0.50MM)	1	UR
6	93332-000U3-00	BEARING	1	
7	688-45567-01-00	SHIM (T:0.10MM)	1	UR
7	688-45567-10-00	SHIM (T:0.12MM)	1	UR
7	688-45567-20-00	SHIM (T:0.15MM)	1	UR
7	688-45567-30-00	SHIM (T:0.18MM)	1	UR
7	688-45567-40-00	SHIM (T:0.30MM)	1	UR
7	688-45567-50-00	SHIM (T:0.40MM)	1	UR
7	688-45567-60-00	SHIM (T:0.50MM)	1	UR
8	93332-00095-00	BEARING	1	

CONTINUED ON NEXT FRAME >

# LOWER CASING DRIVE 1

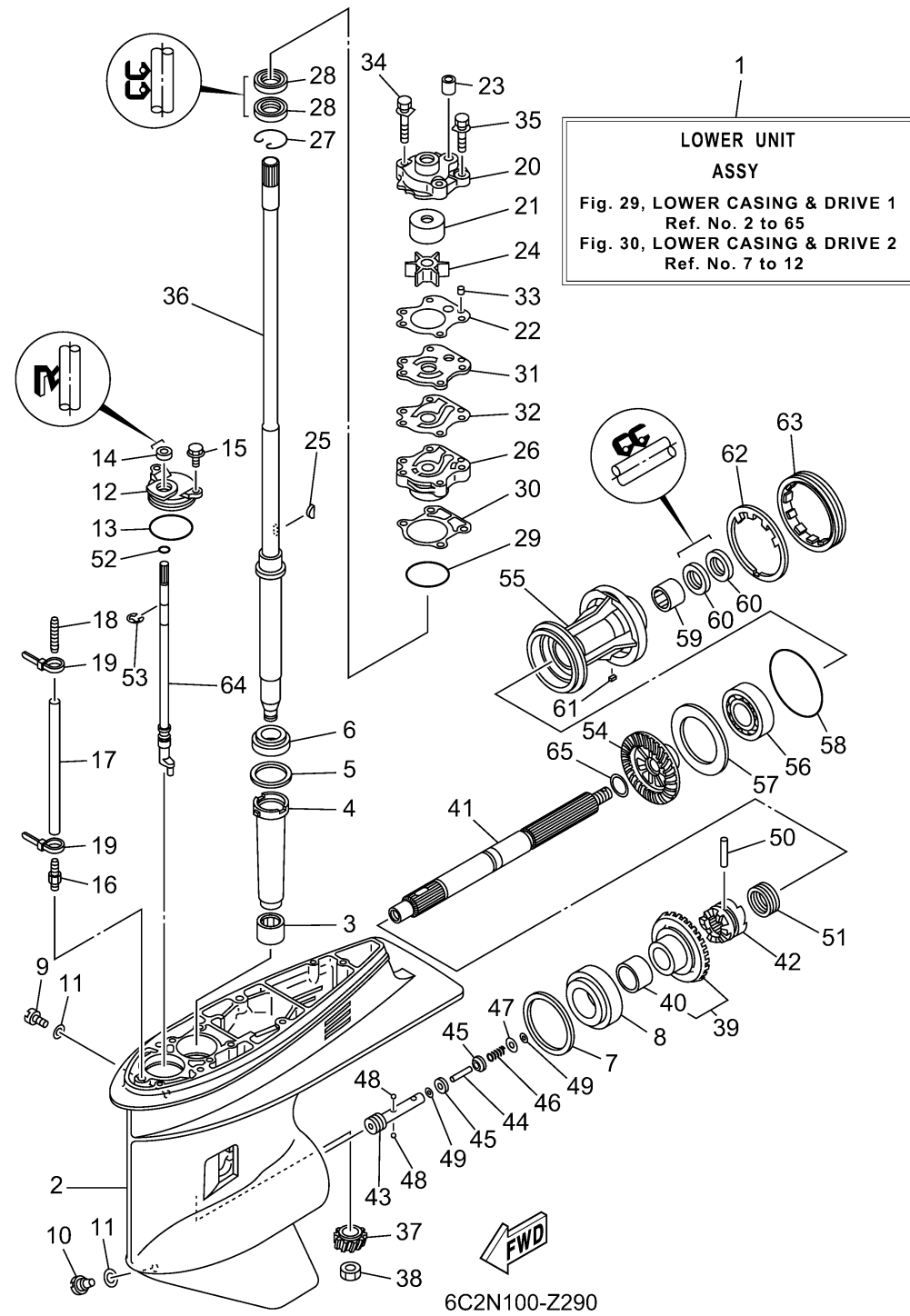

Ref No.	Part Number	Description	Qty	Remarks
9	90340-08002-00	PLUG, STRAIGHT SCREW	1	
10	688-45341-10-00	PLUG, DRAIN	1	
11	90430-08003-00	.GASKET	2	
12	688-45321-00-00	PLATE	1	
13	93210-49046-00	.O-RING	1	
14	93106-09014-00	.OIL SEAL	1	
15	97E95-06516-00	BOLT, HEXAGON W/W DEEP RECESS	2	
16	6E5-45378-00-00	NIPPLE, HOSE	1	
17	90445-07ME8-00	HOSE (L80)	1	L(20.9")
18	6E5-83558-10-00	END, NIPPLE	1	
19	90465-11M10-00	CLAMP	2	
20	6H3-44311-00-00	HOUSING, WATER PUMP	1	
21	663-44322-00-00	.INSERT, CARTRIDGE	1	
22	6H3-44315-A0-00	.GASKET, WATER PUMP	1	
23	663-44366-01-00	.DAMPER, WATER SEAL 2	1	
24	6H3-44352-00-00	.IMPELLER	1	
25	90280-03M03-00	.KEY, WOODRUFF	1	
26	6H3-44341-01-CA	HOUSING, WATER PUMP	1	
27	93450-40165-00	CIRCLIP	1	
28	93101-23070-00	.OIL SEAL	2	

CONTINUED ON NEXT FRAME >

# LOWER CASING DRIVE 1

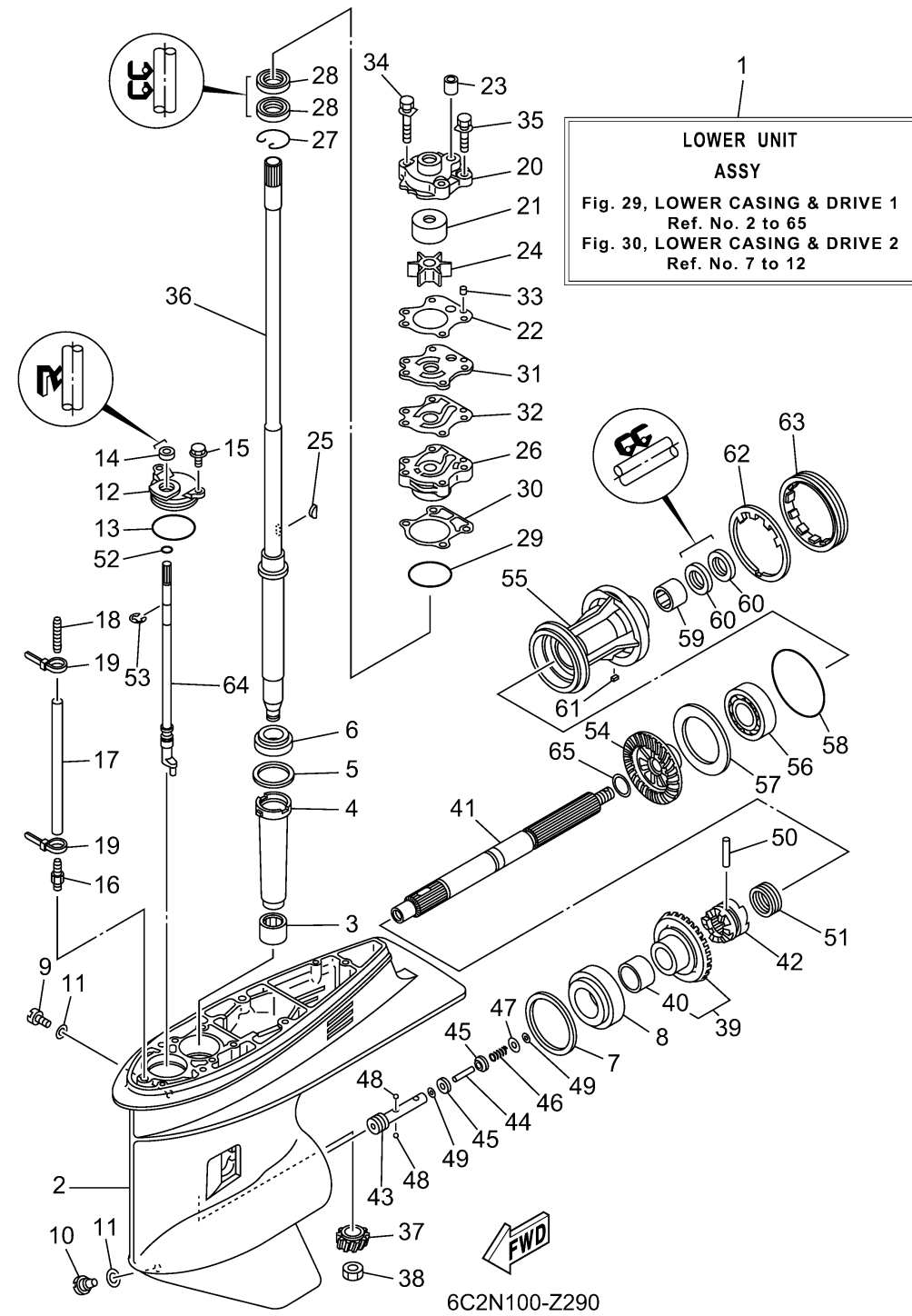

Ref No.	Part Number	Description	Qty	Remarks
29	93210-46044-00	.O-RING	1	
30	688-44316-A0-00	.GASKET, WATER PUMP	1	
31	6H3-44323-00-00	.OUTER PLATE, CARTRIDGE	1	
32	6H3-44324-A0-00	.GASKET, CARTRIDGE	1	
33	93604-10M03-00	.PIN, DOWEL	2	
34	90119-08194-00	.BOLT, WITH WASHER	2	
35	90119-08191-00	.BOLT, WITH WASHER	2	
36	64J-45501-30-00	DRIVE SHAFT COMP.	1	L(20.9")
37	6K5-45551-00-00	PINION (12T)	1	
38	90170-16M01-00	NUT	1	
39	68S-45560-00-00	GEAR 1 (28T)	1	
40	93317-322V0-00	.BEARING	1	
41	67F-45611-01-00	SHAFT, PROPELLER	1	
42	6D8-45631-00-00	CLUTCH, DOG	1	
43	67F-45634-00-00	SLIDE, SHIFT	1	
44	6H1-45668-00-00	SHAFT, FREE 1	1	
45	6H1-45635-00-00	PLUNGER, SHIFT	2	
46	90501-12M48-00	SPRING, COMPRESSION	1	
47	90201-03313-00	WASHER, PLATE	1	
48	93503-16003-00	BALL	2	

CONTINUED ON NEXT FRAME >

# LOWER CASING DRIVE 1

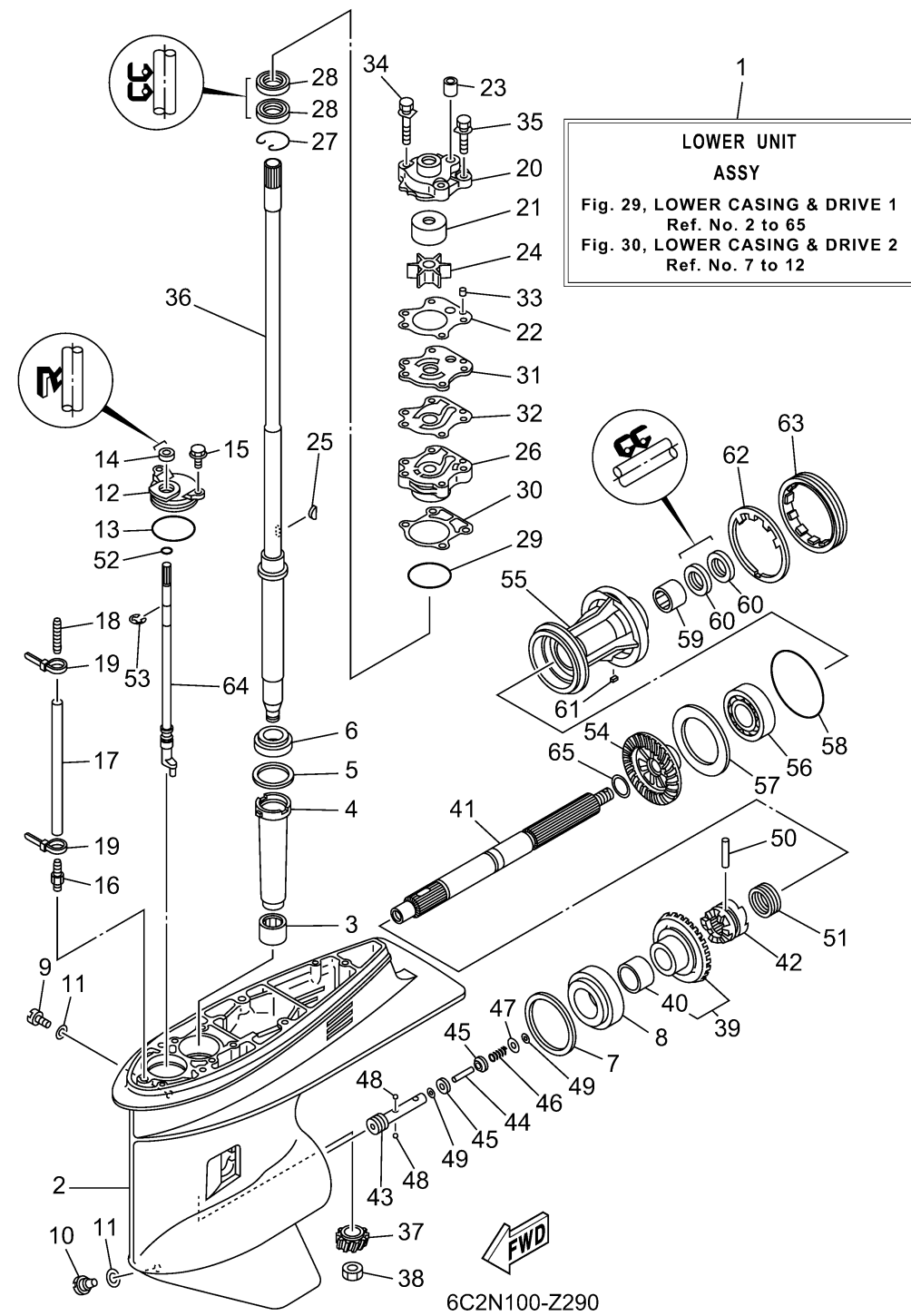

Ref No.	Part Number	Description	Qty	Remarks
49	90183-02M03-00	NUT, SPRING	2	
50	90250-07M02-00	PIN, STRAIGHT	1	
51	688-45633-00-00	RING, CROSS PIN	1	
52	93210-07003-00	.O-RING	1	
53	99001-08600-00	CIRCLIP	1	
54	68S-45571-00-00	GEAR 2 (28T)	1	
55	67F-45331-00-CA	HOUSING, BEARING	1	
56	93306-207U0-00	BEARING	1	
57	67F-45576-00-00	WASHER, THRUST 2	1	
58	93210-86M39-00	.O-RING	1	
59	93317-325U0-00	BEARING	1	
60	93101-25M03-00	.OIL SEAL	2	
61	90282-04010-00	KEY, STRAIGHT	1	
62	688-45383-02-00	WASHER, CLAW	1	
63	688-45384-02-00	NUT	1	
64	64J-44150-01-00	SHIFT CAM ASSY	1	
65	90201-25M05-00	WASHER, PLATE	1	